

# **Stannah**

## **MIDLIFT SL**

### **ELECTRICAL WIRING MANUAL**

**ISSUE:**

**26**

**THIS MANUAL IS TO  
BE LEFT WITH THE  
FOLLOWING  
CONTRACT:**

**STANNAH PART NO:  
912248**

# Stannah

## INDEX

UPDATED DRAWINGS (*)	DRAWING NUMBER	REV	DRAWING DESCRIPTION
	9444/1	O	Midilift SL - main key wiring diagram
	9444/2	K	Midilift SL - carriage component tray connection details
	9444/3	K	Midilift SL - carriage front cover connection details
	9444/102	B	Midilift SL - landing station connection details
	9444/103	B	Midilift SL - landing station connection details with call isolation
	9444/104	B	Midilift SL - landing station cable loom connection details
	9444/117		Midilift SL - second entrance at one level connection details
	9444/105	B	Midilift SL - landing station lock and beak connection details
	9444/86	A	Midilift SL - alarm sounder connection details
*	9444/5	K	Midilift SL - 0.08m/s pump unit connection details
	9444/6	D	Midilift SL - carriage safety edge connection details
	9444/7	D	Midilift SL - pit stop / prop connection details
	9444/9	D	Midilift SL - position switches connection details
	9444/12	L	Midilift SL - automatic door connection details
	9444/19	H	Midilift SL - telephone option connection details
	9444/108	A	Midilift SL - autodial connection details
	9444/126		Midilift SL - shaft roof LED lighting connection details
	9444/32	F	Midilift SL - remote alarm volt free contacts option connection details
	9444/34	G	Midilift SL - carriage cover controls with joystick option
	9444/48	F	Midilift SL - carriage cover DDU connection details
	9444/57	G	Midilift SL - trailer cable connection details
	9444/58	B	Midilift SL - UPS battery back up connection details
	9444/91	C	Midilift SL - relay assembly detail for fire alarm shutdown to ground floor
	9444/107	C	Midilift SL - PLC connection details
*	9444/132	C	Midilift SL - 0.15m/s pump unit connection details
*	9444/131	A	Midilift SL - Videx Intercom connection details
	6101110	A	Midilift SL - earth bonding connection details

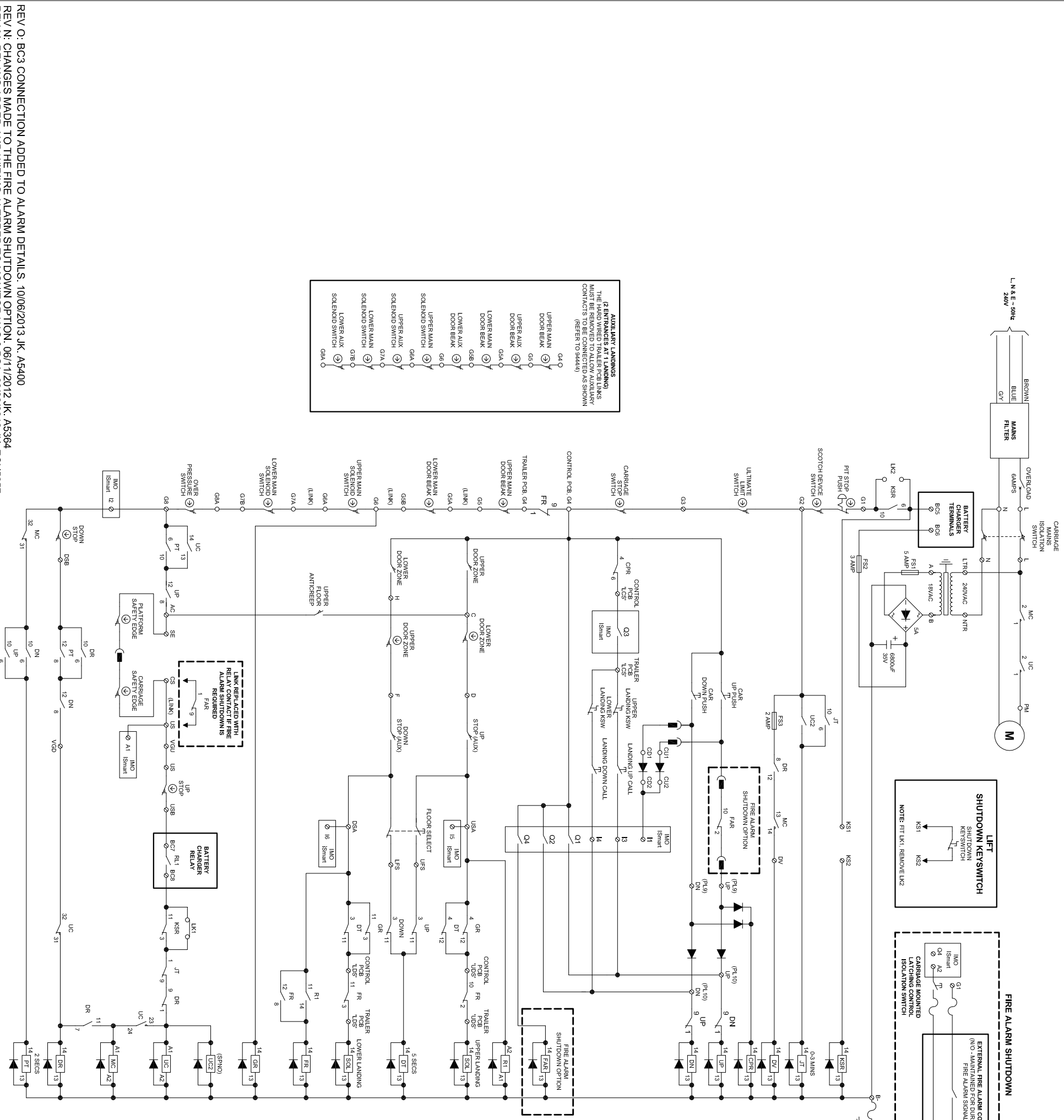

**TRAILER LANDINGS**  
 (2 FUSES & 4 RELAYS)  
 THE HARD WIRED TRAILER PCB LINKS  
 MUST BE REMOVED TO ALLOW AUXILIARY  
 CONTACTS TO BE CONNECTED AS SHOWN  
 (REFER TO 9444/1)

**SAFETY NOTE:**  
 TURN OFF 'LATCHING ISOLATION' SWITCH  
 DURING INSTALLATION, INSPECTION AND  
 WHENEVER CARTRIDGE COVER IS REMOVED.  
 THIS DISABLES LATCHED LANDINGS AND FIRE  
 ALARM SHUTDOWN.

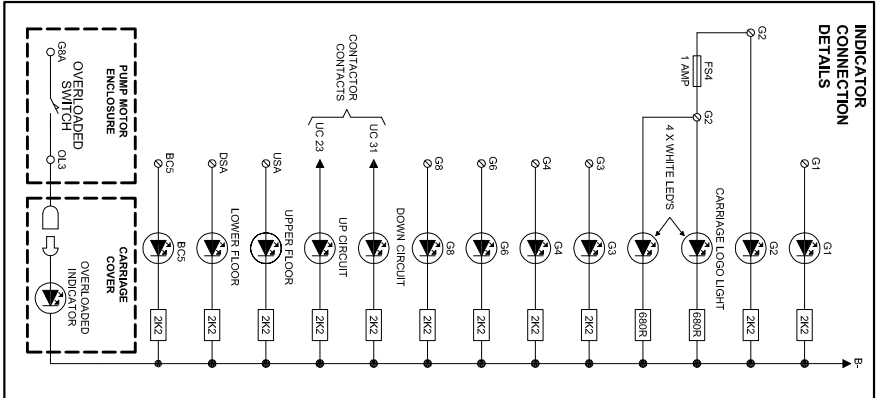
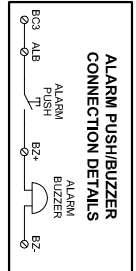

REV O: BC3 CONNECTION ADDED TO ALARM DETAILS. 10/06/2013 JK. AS400  
 REV N: CHANGES MADE TO THE FIRE ALARM SHUTDOWN OPTION. 06/11/2012 JK. AS364  
 REV M: RELAYS ADDED AND WIRING ALTERED TO MONITOR UAS & DSA. 03/02/2012 JN. EON6257  
 REV L: PAUSE TIMER CHANGED TO 2 SECONDS. 30/11/2011 JK. AS115  
 REV K: UPDATED FOR NEW LOGO AND TEXT FONT. 13/09/2010 JN.  
 REV J: PLC ADDED. TO INCORPORATE LATCH LANDINGS AS STANDARD. 13/05/10 JN A4476  
 REV I: AUXILIARY LANDING OPERATIONS NOW VIA GPR RELAY CONTACT AND DIODE MATRIX. CARTRIDGE/PLATFORM SAFETY EDGE MOVED AFTER AC TERMINAL IN UP RUN CIRCUIT 02/01/07 MH  
 REV H: CAR PREFERENCE OPERATION NOW VIA GPR RELAY CONTACT AND DIODE MATRIX. CARTRIDGE/PLATFORM SAFETY EDGE MOVED AFTER AC TERMINAL IN UP RUN CIRCUIT 02/01/07 MH  
 REV G: BCS AND G4 LED ADDED & CAR AND LANDING CALL FEED TAKEN FROM G4 20/06/06 MH  
 REV F: CARTRIDGE LOGO LAMPS REPLACED WITH LEDS 06/03/03 MH  
 REV E: UP AND DOWN RELAYS INTERLOCKED 03/12/02 MH  
 REV D: KEYSWITCH LABELLING ALTERED TO MEET BSI REQUIREMENTS 09/12/02 MH  
 REV C: SCOTCH DEVICE SAFETY SWITCH ADDED 11/11/02 MH  
 REV B: CONNECTION DETAILS ALTERED TO INCLUDE TRAILER CONNECTION PCB AND OVERLOADED INDICATION 12/08/02 MH  
 REV A: COMPONENT LABELS ALTERED 01/07/02 MH

NAME: M.HOOD DATE: 21/05/02  
 CHECKED: R.BAUGH DATE: 21/05/02  
 MIDLIFT SL - MAIN KEY  
 WIRING DIAGRAM

HEAD OFFICE:  
 Antton Mill  
 Andover Hampshire  
 SP10 2NX England  
 Tel: 01264 339090 Fax: 337942

DRAWING NO: 9444/1 REV: O



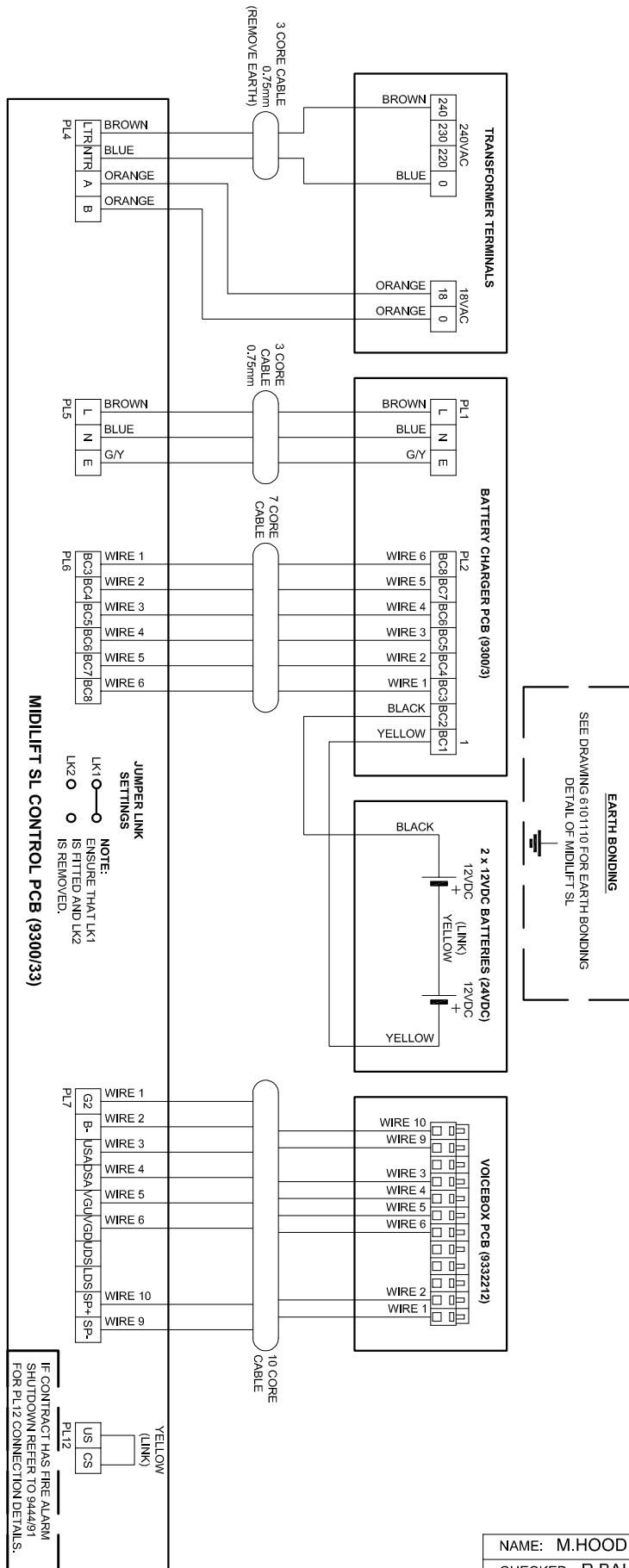

**EARTH BONDING**

SEE DRAWING 6101110 FOR EARTH BONDING DETAIL OF MIDILIFT SL

NAME: M.HOOD	DATE: 22/05/02
CHECKED: R.BAUGH	DATE: 22/05/02
<b>MIDILIFT SL CARRIAGE COMPONENT TRAY CONNECTION DETAILS</b>	
<b>HEAD OFFICE:</b> Anton Mill Andover Hampshire SP10 2NX England Tel: 01264 339090 Fax: 337942	
DRAWING NO: 9444/2	REV: K

REV K: 18VDC CHANGED TO 18VAC ON THE TRANSFORMER TERMINALS. 10/06/2013 JK, A5400.  
 REV J: WIRES 7 & 8 FROM VOICE UNIT REMOVED AND UPDATED FOR NEW LOGO AND TEXT FONT. 13/09/2010 JN.  
 REV I: PL12 LINK WIRES ADDED & 18V WIRE COLOUR CHANGED TO ORANGE. 29/06/10 JN, A4476  
 REV H: CONNECTIONS REVISED FOR NEW VOICE UNIT 15/12/09 JN  
 REV G: ALARM BUZZER CONNECTION DETAILS REMOVED 26/03/07 MH  
 REV F: USA AND DSA CONNECTIONS MOVED BACK TO PL7. ALARM BUZZER CONNECTION DETAILS ALTERED 02/01/07 MH  
 REV E: USA AND DSA TERMINATIONS ALTERED 20/07/06 MH  
 REV D: UFS & DFS CHANGED TO DSA & USA FOR VOICE PCB CONNECTIONS 29/3/06 DG  
 REV C: EARTH BONDING REFERENCE BOX ADDED DG 14/04/2005  
 REV B: LINK CABLE COLOUR CHANGED FROM YELLOW TO PURPLE 28/11/02 MH  
 REV A: CARRIAGE ISOLATION SWITCH TERMINALS ALTERED 01/07/02 MH

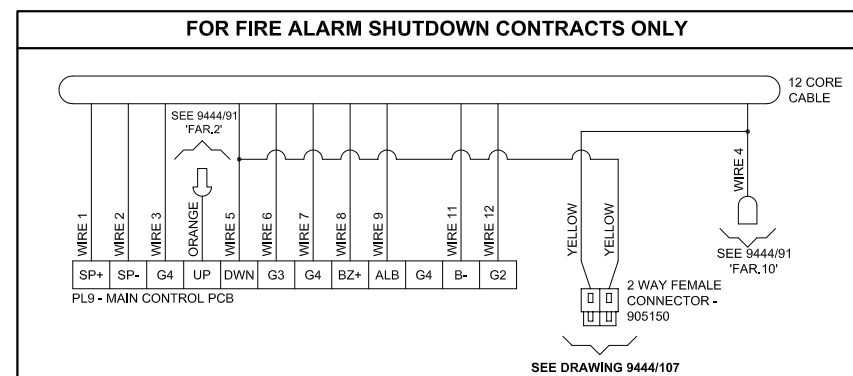
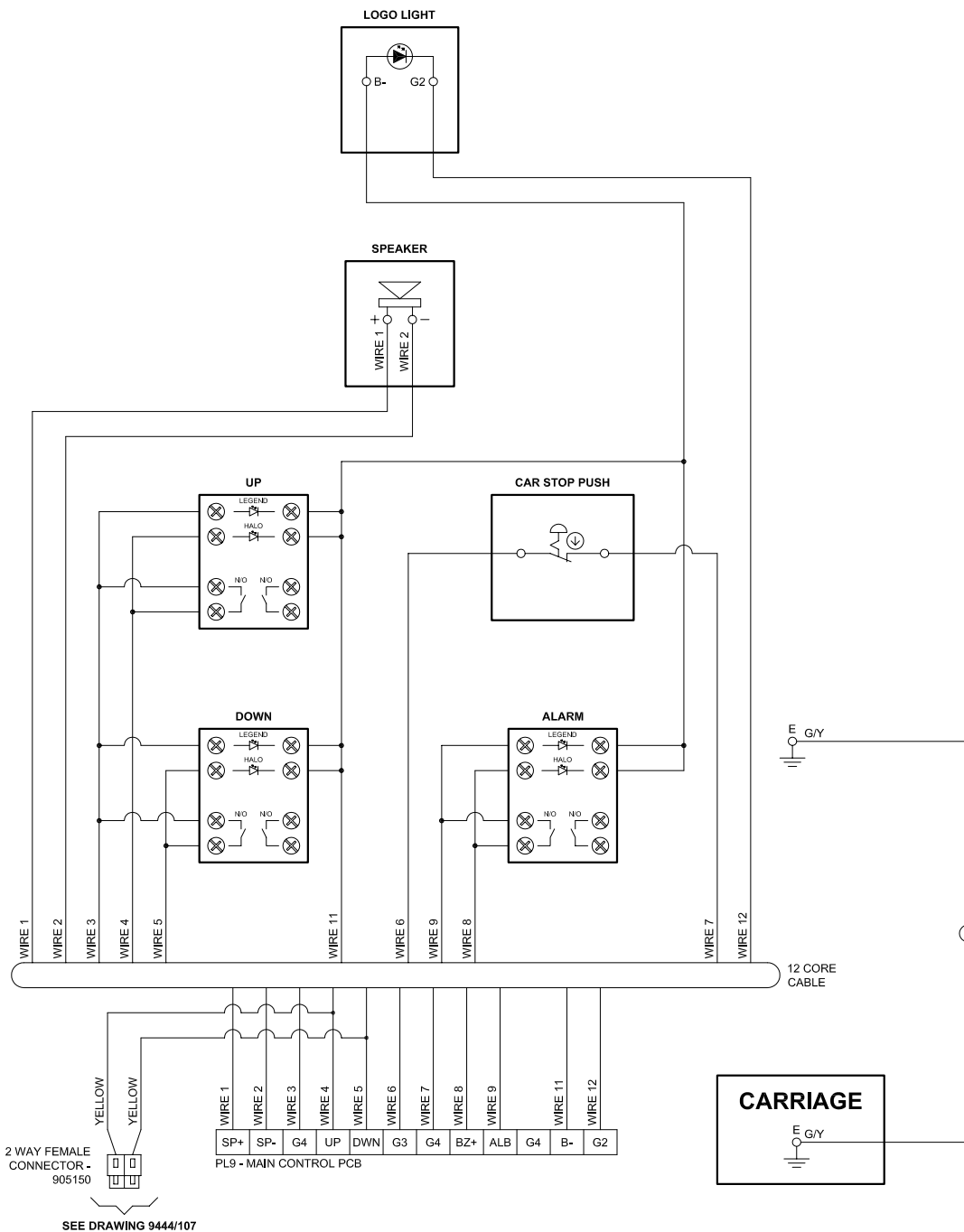

NAME: M.HOOD	DATE: 05/05/09
CHECKED: R.BAUGH	DATE: 05/05/09
<b>MIDLIFT SL - CARRIAGE COVER CONNECTION DETAILS</b>	
<b>Stannah</b>	
HEAD OFFICE: Anton Mill Andover Hampshire SP10 2NX England	
Tel: 01264 339090 Fax: 337942	
DRAWING NO: 9444/3	REV: K

REV K: UPDATED FOR NEW LOGO AND TEXT FONT. 13/09/2010 JN.  
 REV J: 2 WAY WAGO CONN. ADDED TO INCORPORATE LATCH LANDINGS. FIRE ALARM SHUTDAOWN WIRING DETAILS ADDED, 14/05/10 JN. A4476  
 REV I: NEW DEWHURST "M20" PUSH BUTTON CONNECTION DETAILS SHOWN 05/05/09 MH  
 REV H: CONNECTION DETAILS REVISED FOR NEW DEWHURST PUSH BUTTONS 27/03/07 MH  
 REV G: CARRIAGE COVER CONNECTIONS ALTERED AS CAR PREFERENCE IS MAINTAINED BY CPR RELAY 03/01/07 MH  
 REV F: OVERLOAD INDICATOR REMOVED 20/07/04 MH  
 REV E: REMOTE ALARM REFERENCE ADDED 06/03/03 MH  
 REV D: CONNECTION DETAILS OF BI-STABLE STOP SWITCH ADDED 17/02/03 MH  
 REV C: CONNECTION DETAILS OF CAR ALARM PUSH WITH AUTODIAL AND INTERCOM OPTIONS ADDED 06/02/03 MH  
 REV B: NEW LOGO LIGHT PCB CONNECTION DETAILS SHOWN 28/01/03 MH  
 REV A: OVERLOADED INDICATOR CONNECTION DETAILS ADDED 13/08/02 MH

# UPPER/LOWER LANDING STATION

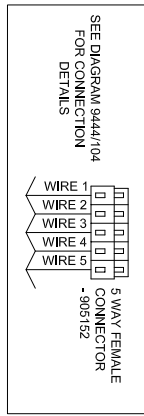
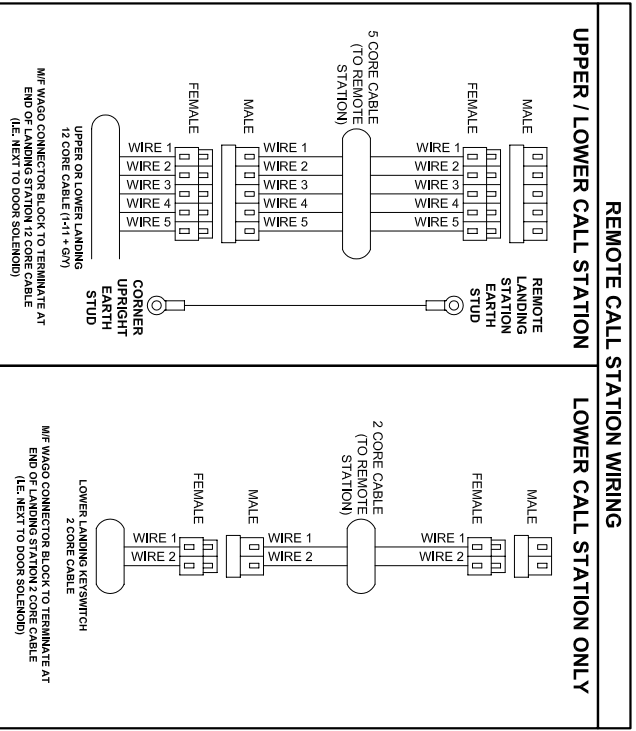
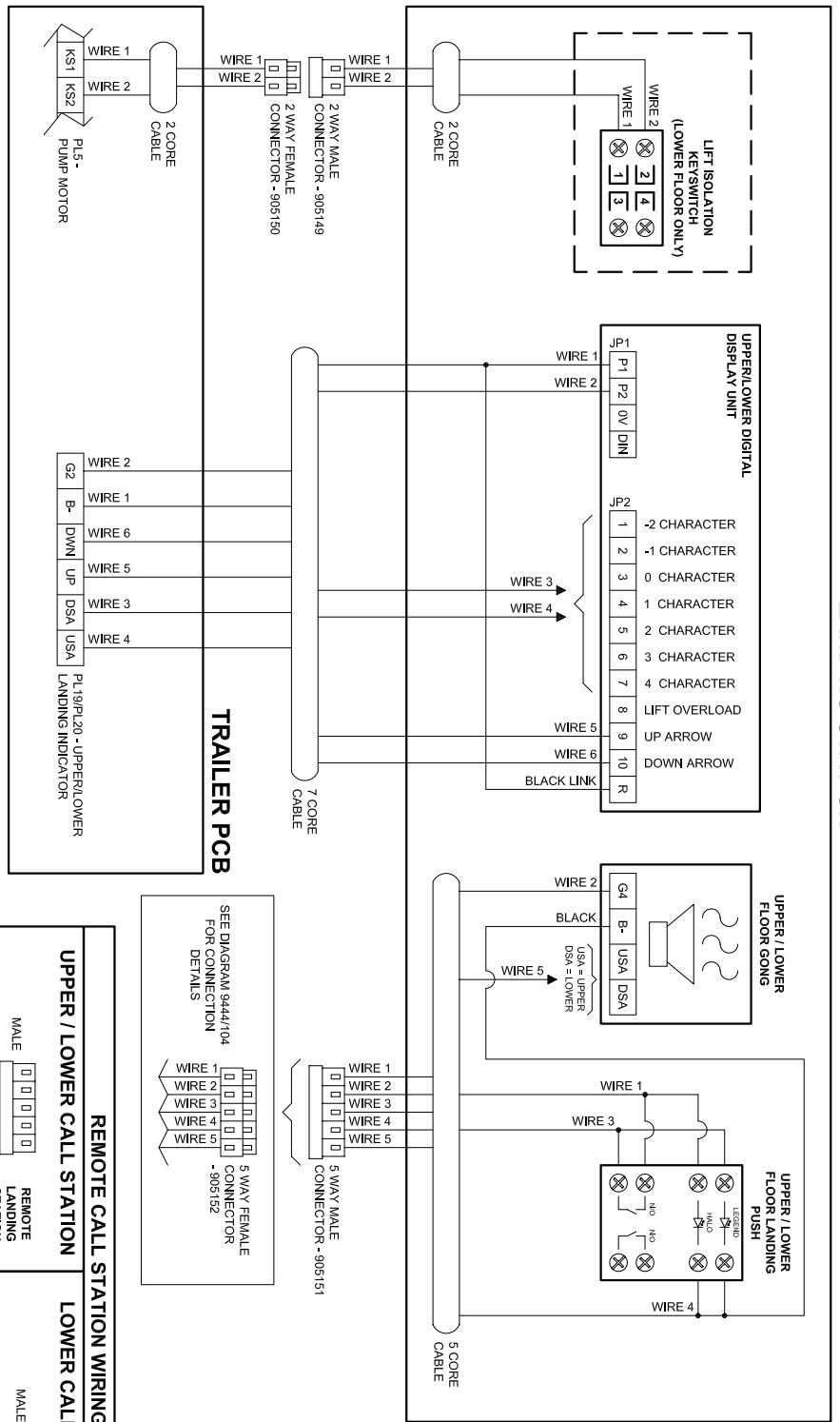

NAME: M.HOOD	DATE: 20/05/09
CHECKED: R.BAUGH	DATE: 20/05/09
<b>MIDLIFT SL LANDING STATION CONNECTION DETAILS</b>	
HEAD OFFICE: <b>Stannah</b> Anton Mill Andover Hampshire SP10 2NX England	
Tel: 01264 339090 Fax: 337942	
DRAWING NO: 9444/102	REV: B

REV B: INCLUDED WIRE WIRING DETAILS FRO REMOTE CALL STATIONS AND UPDATED FOR NEW LOGO AND TEXT FONT . 25/02/2011 JN.

REV A: REFERENCE TO PLUG WIRING ON DIAGRAM 9444/104. 16/03/10 JN

**UPPER/LOWER  
LANDING CONTROL STATION**

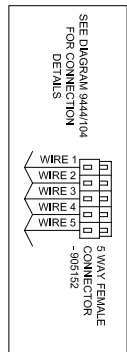
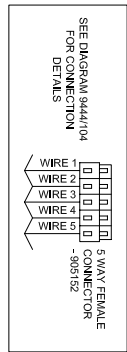
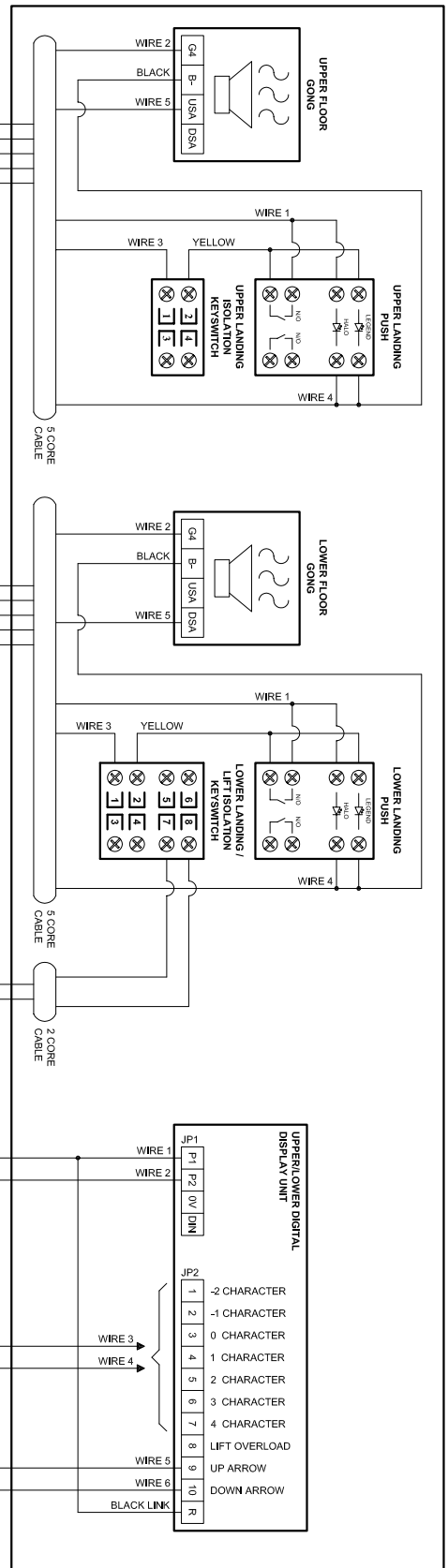

**REMOTE CALL STATION WIRING**

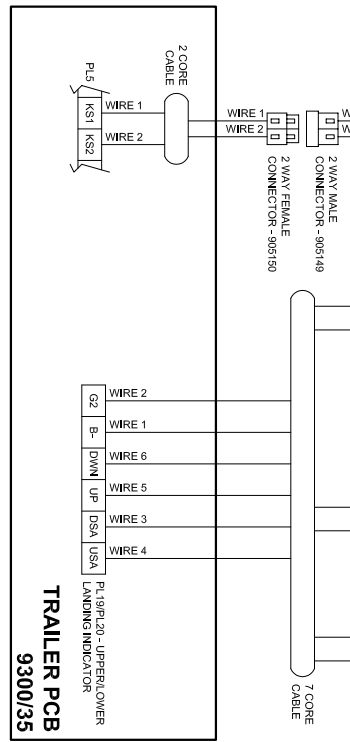
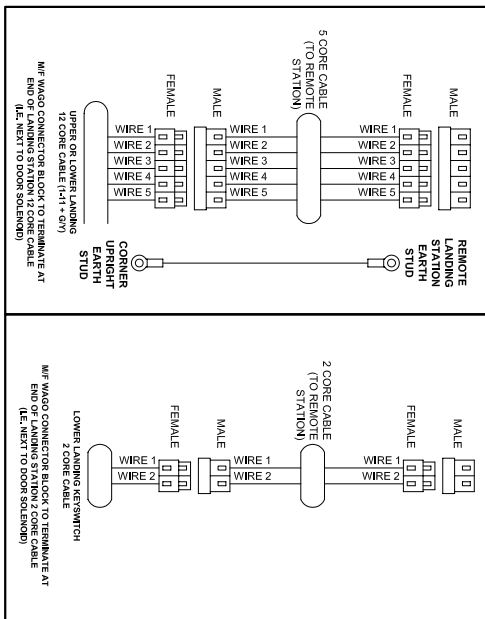

NAME: M.HOOS	DATE: 20/05/09
CHECKED: R.BAUGH	DATE: 20/05/09
<b>MIDLIFT SL LANDING STATION WITH CALL ISOLATION CONNECTION DETAILS</b>	
<b>Stannah</b>	
HEAD OFFICE: Anton Mill Andover Hampshire SP10 2NX England Tel: 01264 339090 Fax: 337942	
DRAWING NO: 9444/103	REV: B

REV B: ADDED WIRING DETAILS FROM REMOTE CALL STATIONS AND UPDATED FOR NEW LOGO AND TEXT FONT . 25/02/2011 JN.  
 REV A: KEYSWITCH ISOLATION RELAY REMOVED, TO INCORPORATE REVISED KEYSWITCH.  
 REFERENCE TO PLUG WIRING ON DIAGRAM 9444/104 ADDED. 16/03/2010 JN

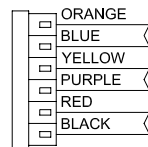
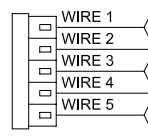
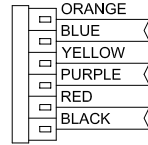
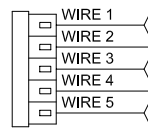

**FOR MALE PLUG CONNECTION SEE -**

9444/103 LANDING CONTROL WITH  
BUTTON ISOLATION  
9444/102 LANDING CONTROL WITHOUT  
BUTTON ISOLATION

**FOR MALE PLUG CONNECTION SEE -**

9444/105 LANDING DOOR LOCK AND  
BEAK CONNECTIONS

CORNER  
UPRIGHT  
EARTH  
STUD

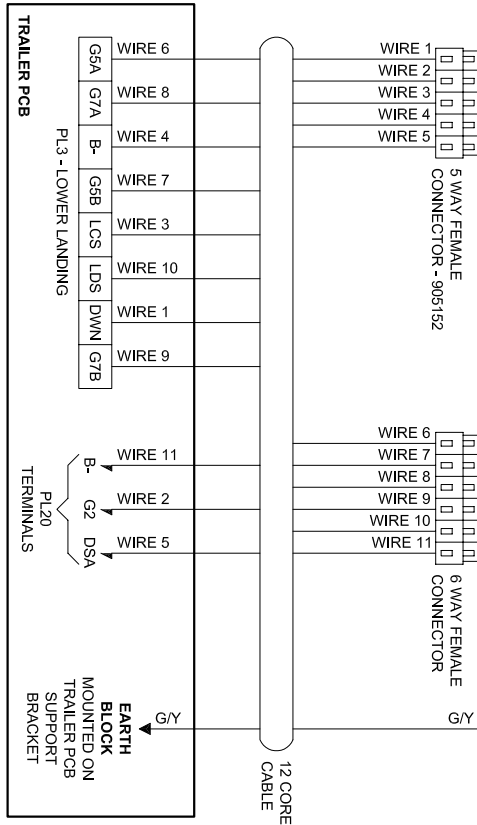

**FOR MALE PLUG CONNECTION SEE -**

9444/103 LANDING CONTROL WITH  
BUTTON ISOLATION  
9444/102 LANDING CONTROL WITHOUT  
BUTTON ISOLATION

CORNER  
UPRIGHT  
EARTH  
STUD

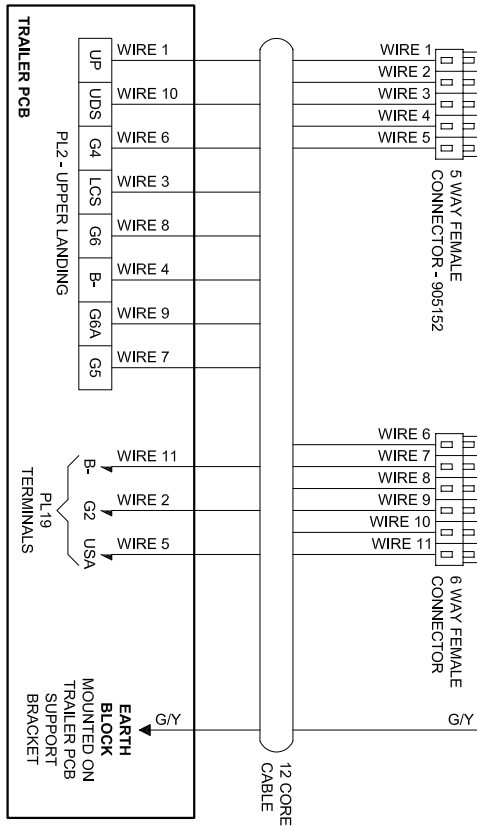

NAME: M.HOOD DATE: 20/05/09  
CHECKED: R.BAUGH DATE: 20/05/09

MIDLIFT SL  
LANDING STATION CABLE LOOM  
CONNECTION DETAILS

**Stannah**

HEAD OFFICE:  
Anton Mill  
Andover Hampshire  
SP10 2NX England

Tel: 01264 339090 Fax: 337942

DRAWING NO: 9444/104

REV: B



**CONNECTION DETAILS FOR SINGLE LANDING ENTRANCE  
TRAILER CONNECTION PCB (9300/35) TERMINATIONS**

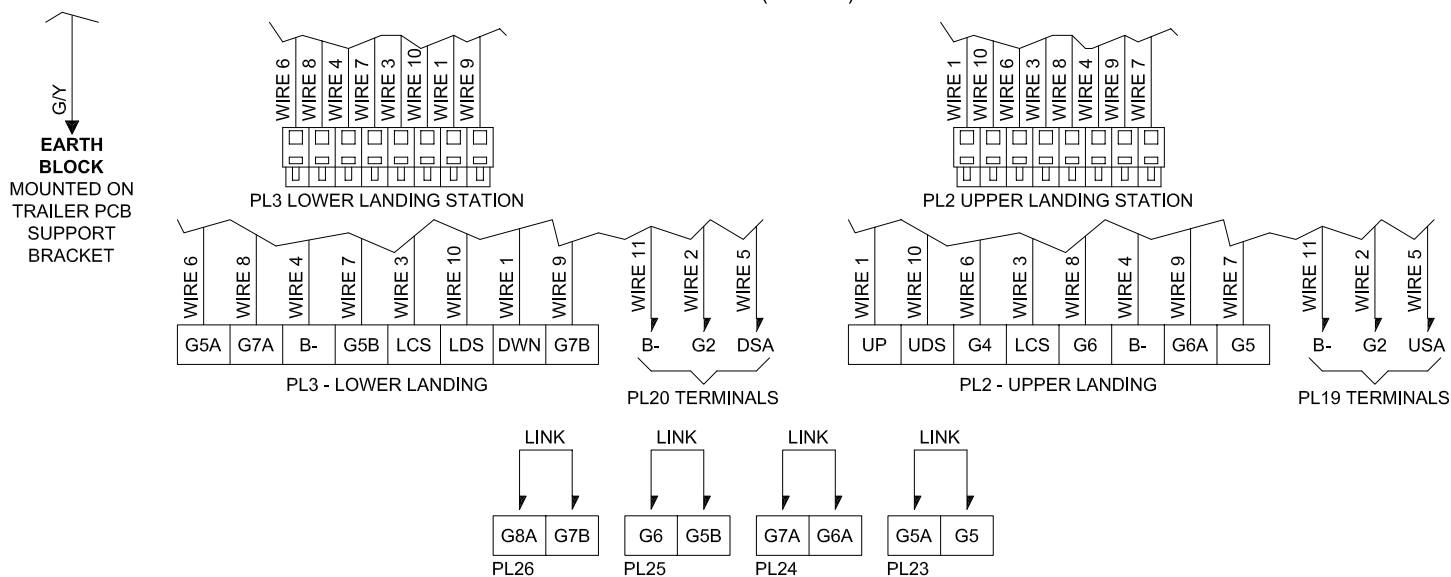

**IMPORTANT NOTE:**

IF LANDING IS TO HAVE ONLY A SINGLE ENTRANCE THE CORRESPONDING SOLENOID SWITCH AND BEAK CONTACT SHORTING LINKS **MUST BE ADDED** TO TRAILER PCB AS SHOWN ABOVE.

**CONNECTION DETAILS FOR SECOND ENTRANCE AT ONE LEVEL  
TRAILER CONNECTION PCB (9300/35) TERMINATIONS**

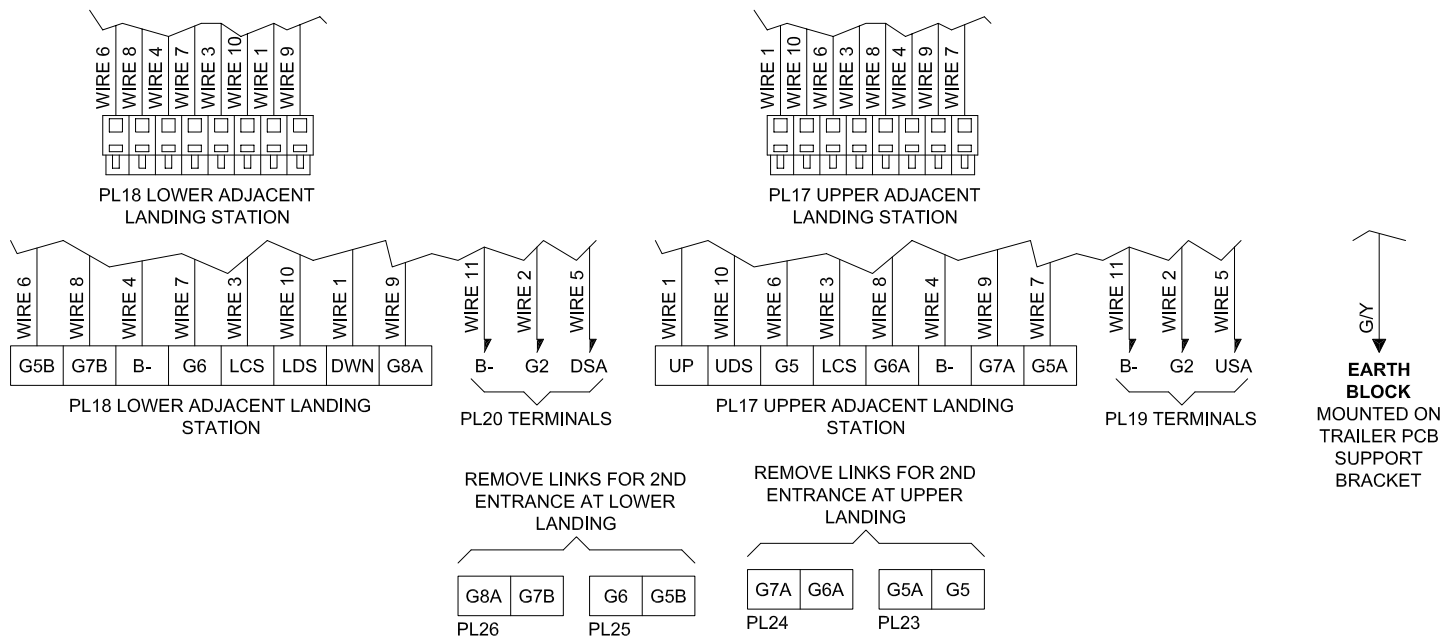

**IMPORTANT NOTE:**

IF TWO ENTRANCES ARE REQUIRED AT ONE LANDING THE CORRESPONDING SOLENOID SWITCH AND BEAK CONTACT SHORTING LINKS **MUST BE REMOVED** FROM THE TRAILER PCB AS SHOWN ABOVE.

NAME: J.NICHOLLS DATE: 26/01/11  
CHECKED: M.HOOD DATE: 26/01/11

MIDLIFT SL 2 STOP  
SECOND ENTRANCE AT ONE LEVEL  
WIRING DETAILS

**Stannah**

HEAD OFFICE:  
Anton Mill  
Andover Hampshire  
SP10 2NX England

Tel: 01264 339090 Fax: 337942

DRAWING NO: 9447/117

REV:

# UPPER/LOWER LANDING STATION DOOR LOCK

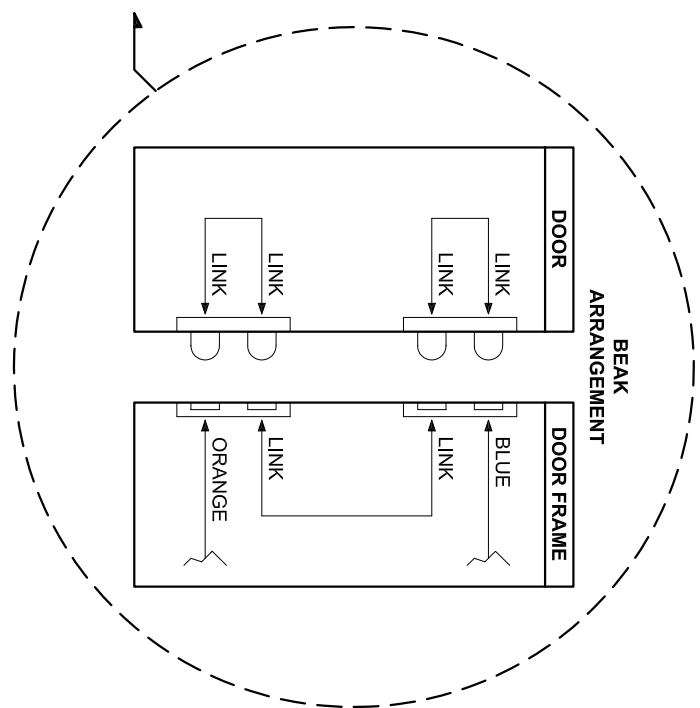
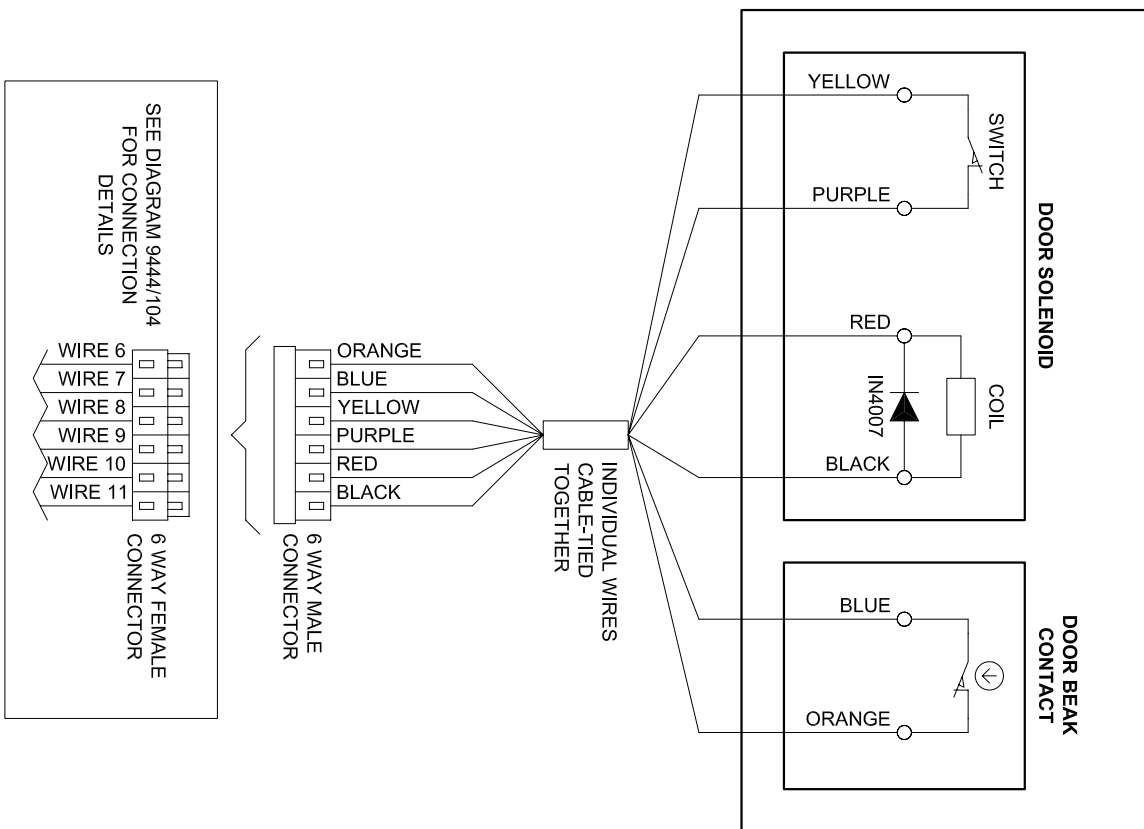

NAME: M.HOOD	DATE: 03/06/09
CHECKED: R.BAUGH	DATE: 03/06/09
LANDING DOOR LOCK AND BEAK CONNECTION DETAILS	
	
HEAD OFFICE: Anton Mill Andover Hampshire SP10 2NX England Tel: 01264 339090 Fax: 337942	
DRAWING NO: 9444/105	REV: B

**TRAILER PCB  
MOUNTED WITHIN GUIDE**

PL21

BZ+ B-

WIRE 1

WIRE 2

2 CORE  
NUMBERED  
(0.5MM)

**ALARM SOUNDER**

WIRE 2

WIRE 1

1 2 3 4 5 6

**BIT SWITCHES**

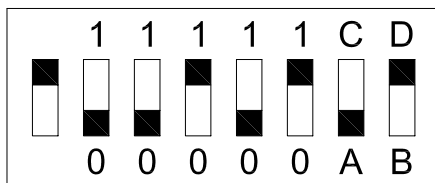

**IMPORTANT NOTES:**

1. ALARM TO BE MOUNTED WITHIN A 5 METRE RADIUS OF THE LIFT.
2. SET BIT SWITCHES AS SHOWN.

NAME: M.HOOD DATE: 03/04/07

CHECKED: R.BAUGH DATE: 03/04/07

MIDLIFT SL  
ALARM SOUNDER  
CONNECTION DETAILS

**Stannah**

HEAD OFFICE:  
Anton Mill  
Andover Hampshire  
SP10 2NX England

Tel: 01264 339090 Fax: 337942

DRAWING NO: 9444/86

REV: A

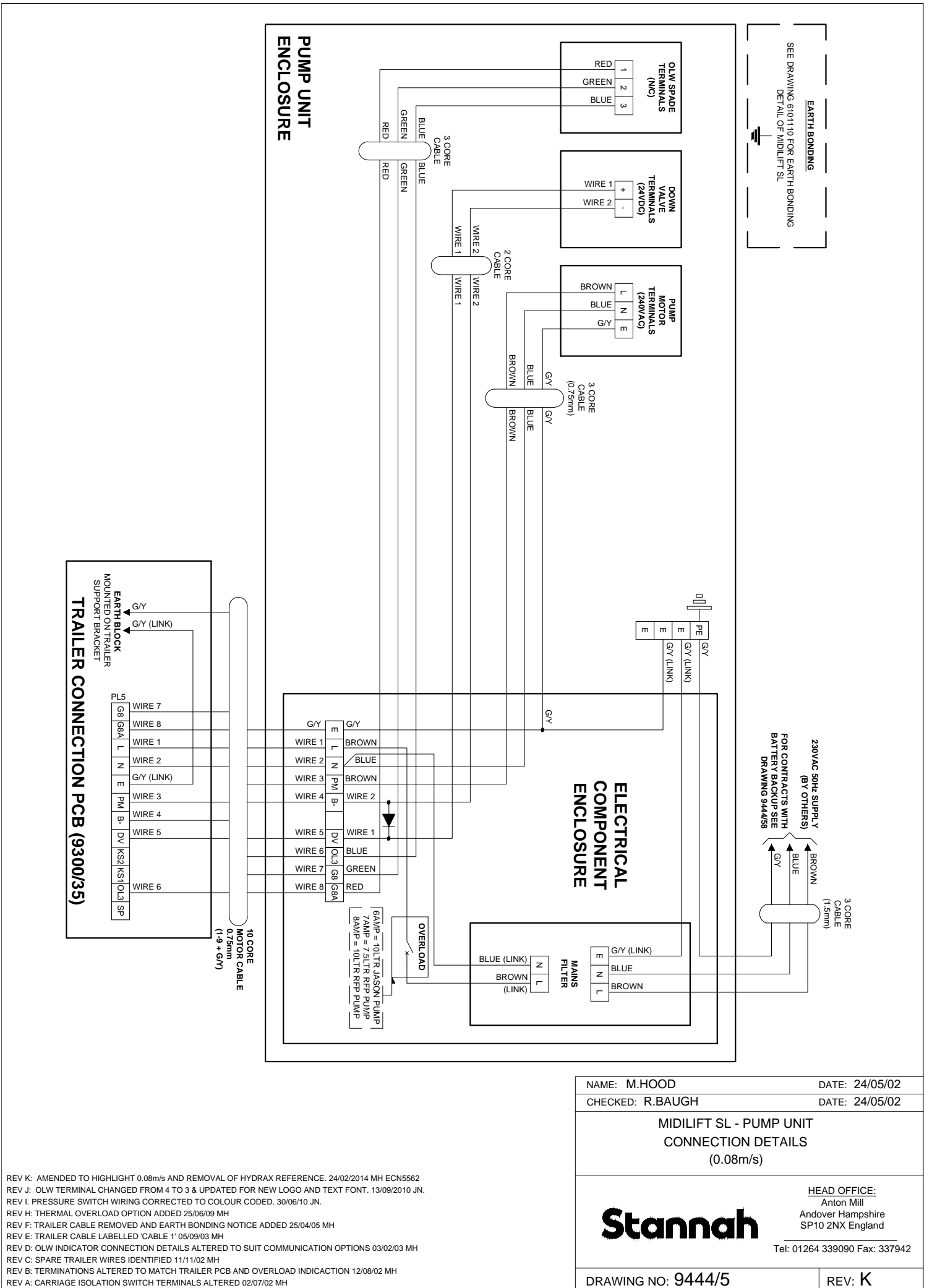

REV K: AMENDED TO HIGHLIGHT 0.08m/s AND REMOVAL OF HYDRAX REFERENCE. 24/02/2014 MH ECN5562  
 REV J: OLW TERMINAL CHANGED FROM 4 TO 3 & UPDATED FOR NEW LOGO AND TEXT FONT. 13/09/2010 JN.  
 REV I: PRESSURE SWITCH WIRING CORRECTED TO COLOUR CODED. 30/06/10 JN.  
 REV H: THERMAL OVERLOAD OPTION ADDED 25/06/09 MH  
 REV F: TRAILER CABLE REMOVED AND EARTH BONDING NOTICE ADDED 25/04/05 MH  
 REV E: TRAILER CABLE LABELLED 'CABLE 1' 05/09/03 MH  
 REV D: OLW INDICATOR CONNECTION DETAILS ALTERED TO SUIT COMMUNICATION OPTIONS 03/02/03 MH  
 REV C: SPARE TRAILER WIRES IDENTIFIED 11/11/02 MH  
 REV B: TERMINATIONS ALTERED TO MATCH TRAILER PCB AND OVERLOAD INDICATION 12/08/02 MH  
 REV A: CARRIAGE ISOLATION SWITCH TERMINALS ALTERED 02/07/02 MH

NAME: M.HOOD	DATE: 24/05/02
CHECKED: R.BAUGH	DATE: 24/05/02
<b>MIDLIFT SL - PUMP UNIT          CONNECTION DETAILS          (0.08m/s)</b>	
	
<b>HEAD OFFICE:</b> Anton Mill Andover Hampshire SP10 2NX England Tel: 01264 339090 Fax: 337942	
DRAWING NO: 9444/5	REV: K

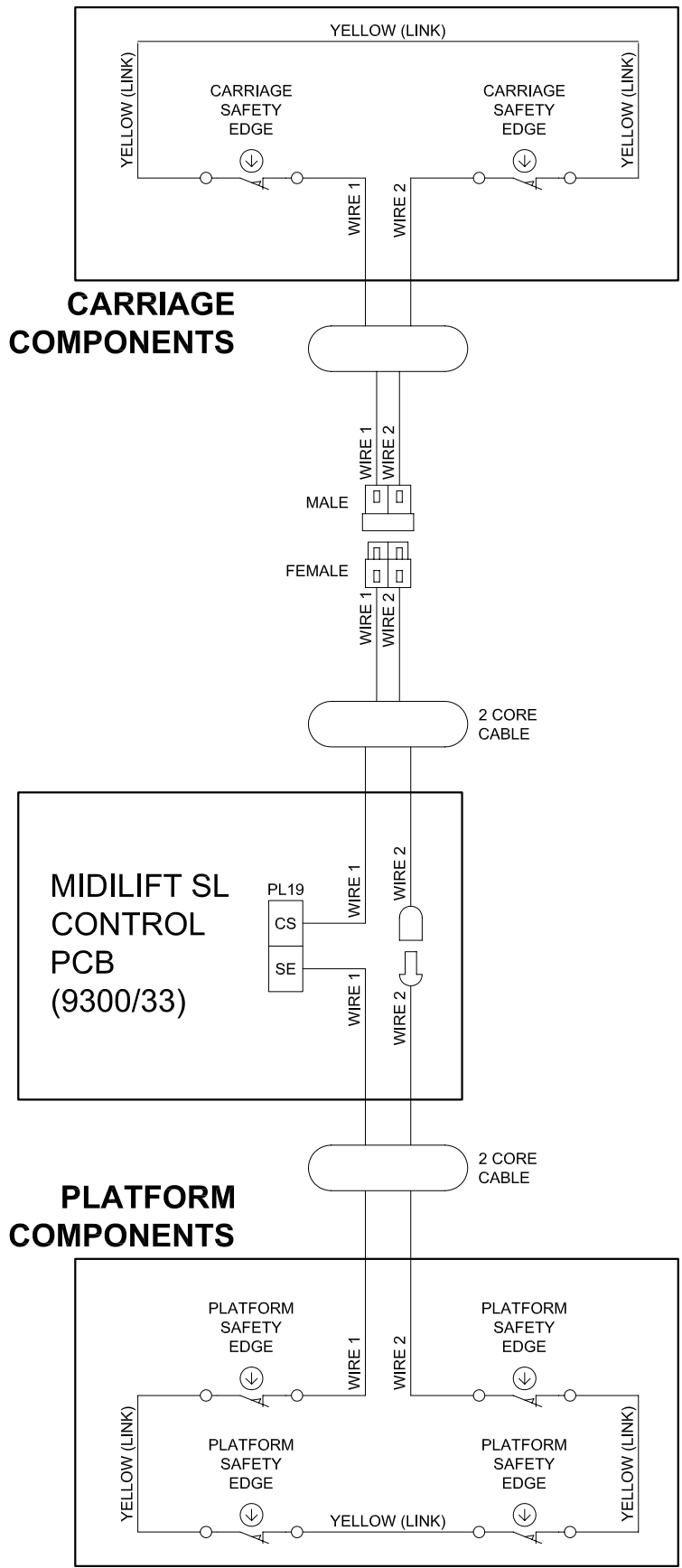

NAME: M.HOOD	DATE: 24/05/02
CHECKED: R.BAUGH	DATE: 24/05/02

**MIDLIFT SL - SAFETY EDGE CONNECTION DETAILS**

<h1>Stannah</h1>	HEAD OFFICE: Anton Mill Andover Hampshire SP10 2NX England
	Tel: 01264 339090 Fax: 337942

DRAWING NO: 9444/6	REV: D
--------------------	--------

REV D: ADDITIONAL CONNECTORS INCLUDED TO ALLOW TOP CARRIAGE SECTION TO BE REMOVED. 23/05/2011 MH A4951.  
 REV C: UPDATED FOR NEW LOGO AND TEXT FONT. 13/09/2010 JN.  
 REV B: CARRIAGE & PLATFORM CONNECTION DETAILS ALTERED 28/06/10 JN. A4476  
 REV A: CARRIAGE SAFETY CHAIN MOVED. CONNECTION DETAILS ALTERED 03/01/07 MH

## SHAFT SAFETY SWITCHES

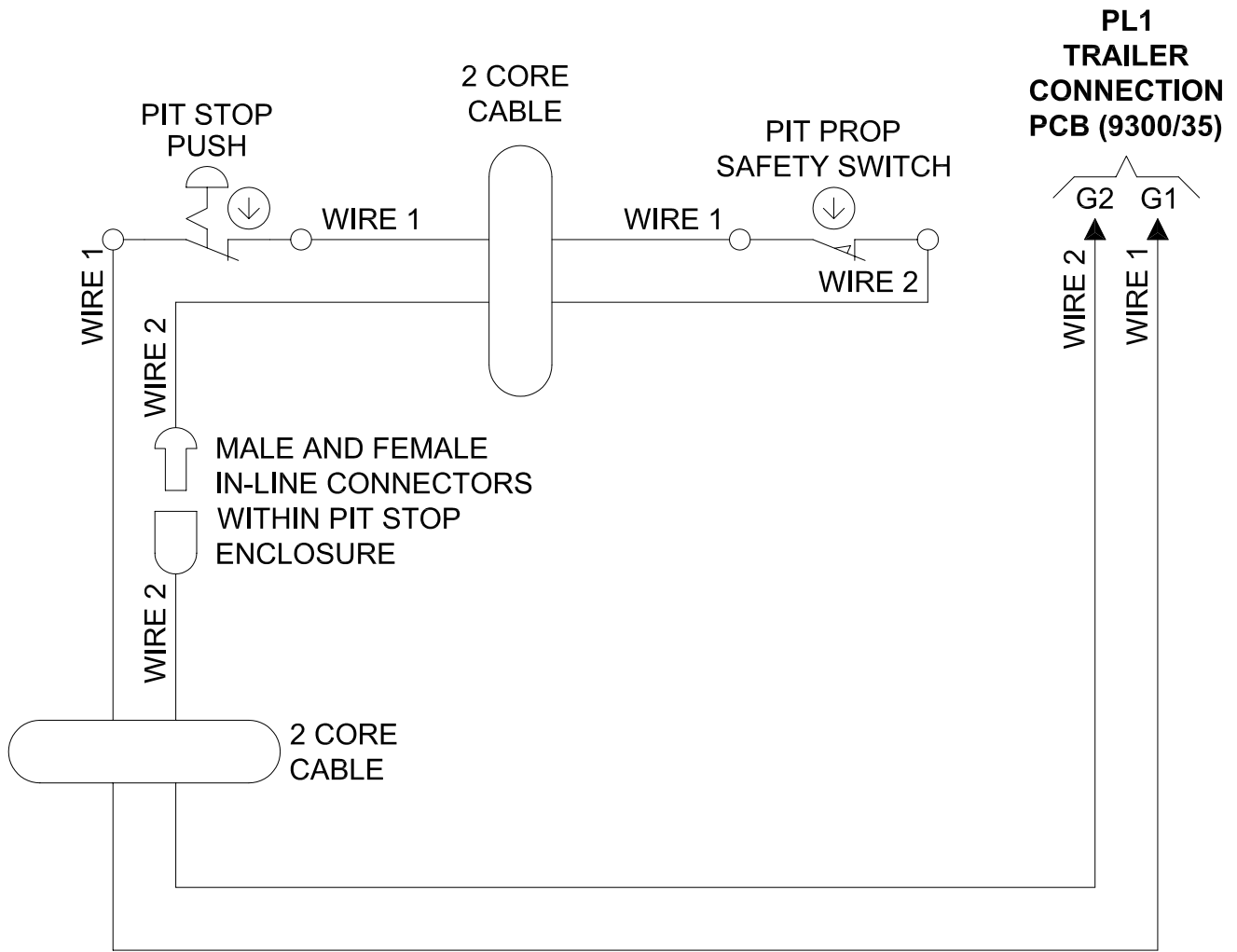

NAME: M.HOOD	DATE: 24/05/02
CHECKED: R.BAUGH	DATE: 24/05/02

MIDLIFT SL  
PIT/PROP CONNECTION DETAILS

# Stannah

HEAD OFFICE:  
Anton Mill  
Andover Hampshire  
SP10 2NX England

Tel: 01264 339090 Fax: 337942

DRAWING NO: 9444/7

REV: D

REV D: UPDATED FOR NEW LOGO AND TEXT FONT. 13/09/2010 JN.  
REV C: SHUTDOWN KEYSWITCH DETAIL REMOVED 27/05/09 MH  
REV B: DETAIL OF NEW KEYSWITCH ADDED 26/06/06 MH  
REV A: PIT SAFETY SWITCH CONNECTION DETAIL ADDED 26/04/05 MH

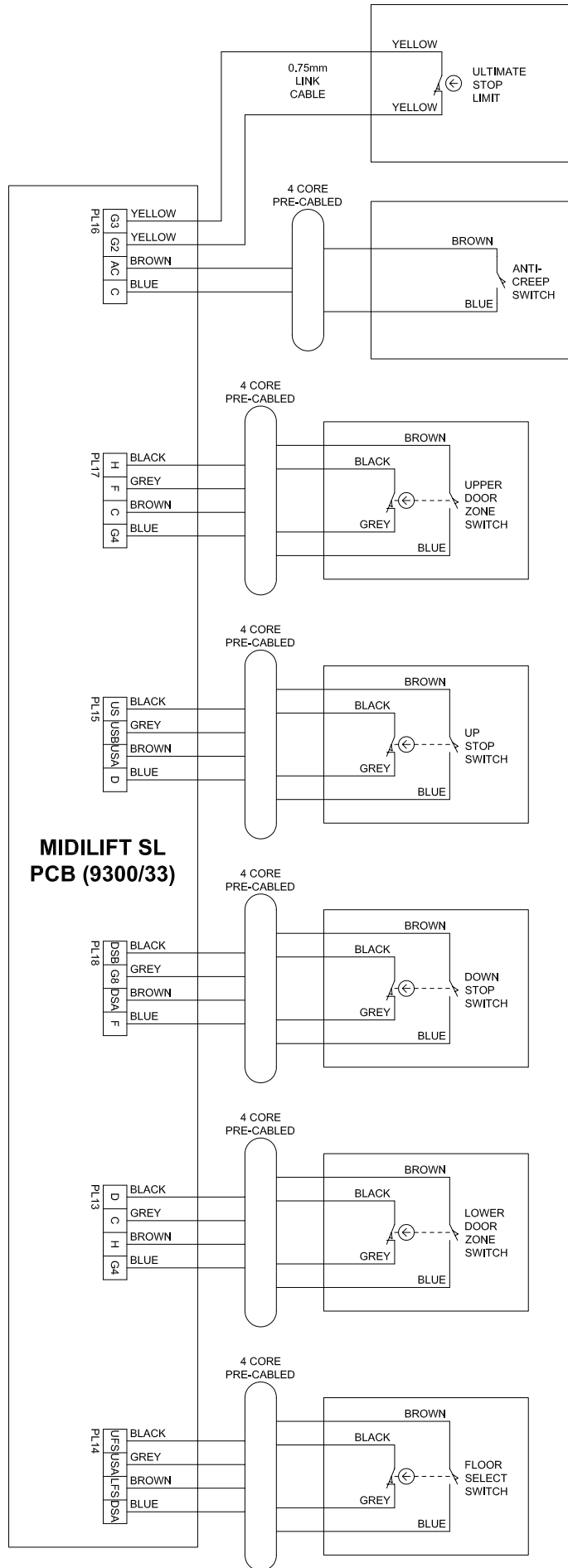

**MIDILIFT SL  
PCB (9300/33)**

**BACK CARRIAGE  
MOUNTED  
POSITION  
SWITCHES**

NAME: M.HOOD	DATE: 27/05/02
CHECKED: R.BAUGH	DATE: 27/05/02

**MIDILIFT SL  
POSITION SWITCHES  
CONNECTION DETAILS**

**Stannah**

HEAD OFFICE:  
Anton Mill  
Andover Hampshire  
SP10 2NX England

Tel: 01264 339090 Fax: 337942

DRAWING NO: 9444/9

REV: D

REV D: UPDATED FOR NEW LOGO AND TEXT FONT. 13/09/2010 JN.  
REV C: UP STOP TERMINATIONS ALTERED 03/01/07 MH  
REV B: CABLE COLOUR ALTERED TO MATCH PRE-WIRED SWITCHES 28/07/04 MH  
REV A: ULTIMATE STOP LIMIT CONNECTIONS ALTERED 02/07/02 MH

**SPRINT AUTO DOOR - FOR STANDARD DOORS/GATES ONLY**

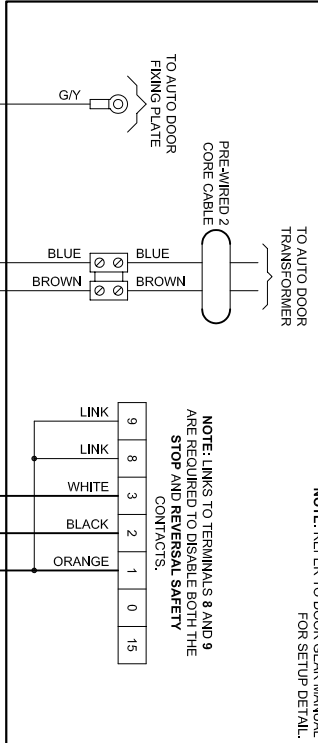
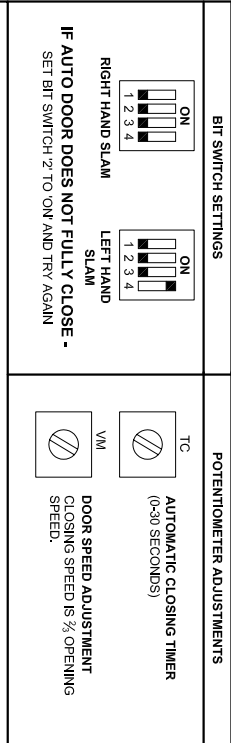

**TRANSIT WEL E AUTO DOOR - FOR FIREDOORS ONLY**

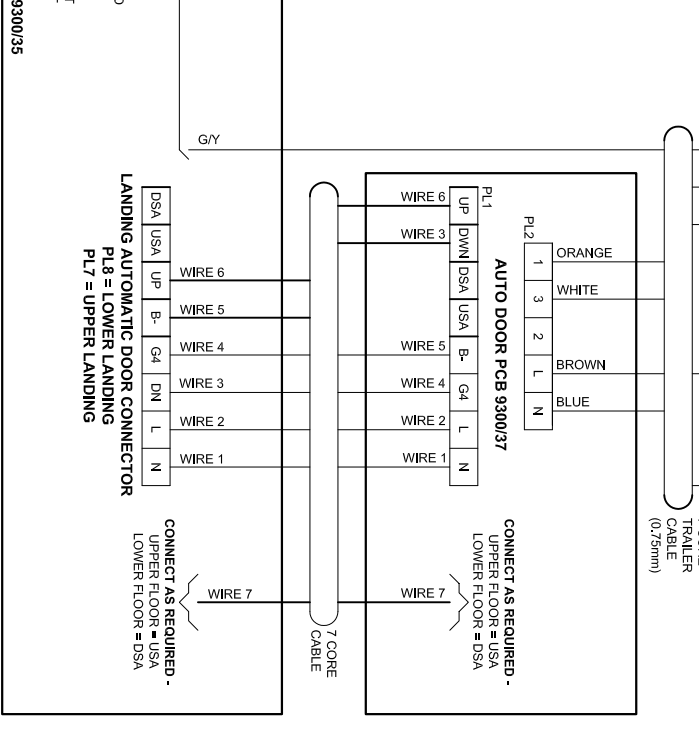
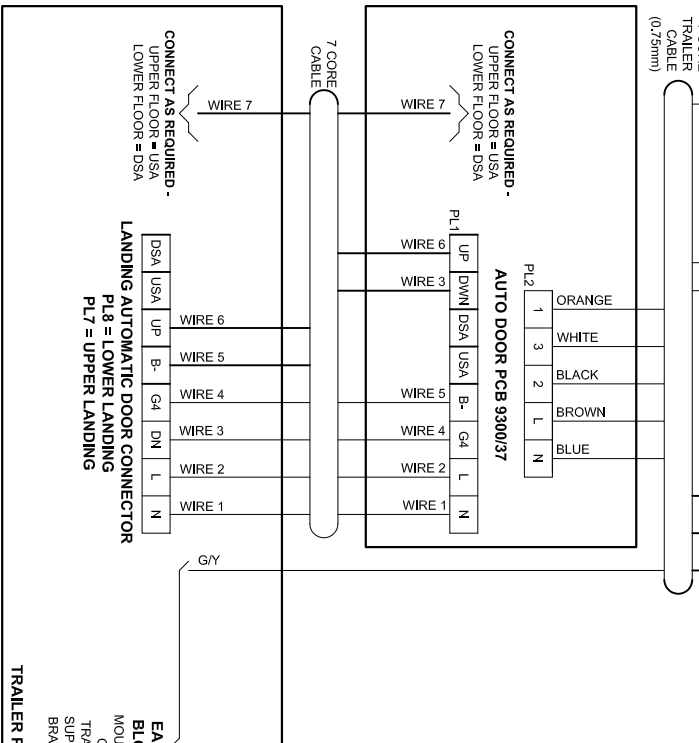
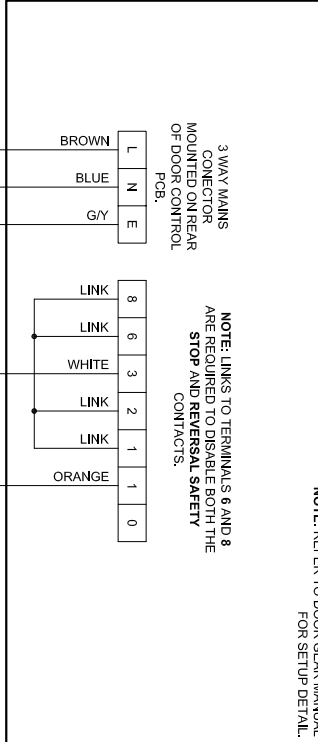
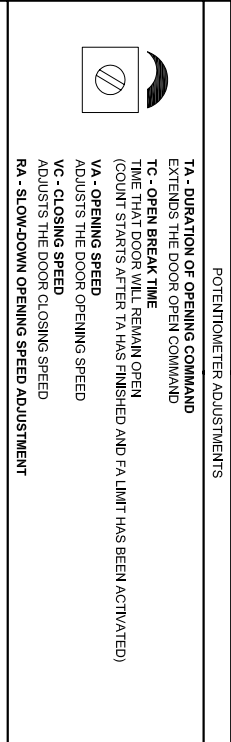

NAME: M.HOOD	DATE: 12/08/02
CHECKED: R.BAUGH	DATE: 12/08/02
<b>MIDLIFT SL AUTO DOOR CONNECTION DETAILS</b>	
HEAD OFFICE: Anton Mill Andover Hampshire SP10 2NX England Tel: 01264 339090 Fax: 337942	
DRAWING NO: 9444/12	REV: L

REV L: UPDATED FOR NEW LOGO AND TEXT FONT, 13/09/2010 JN.  
 REV K: TRAILER CABLE NOTE CORRECTED 16/06/09 MH  
 REV J: UPPER/LOWER FLOOR NOTE ADDED 14/01/09 MH  
 REV I: TRANSIT AUTO DOOR CONNECTIONS REVISED FOR NEW 'WEL UE' MODEL 16/05/08 MH  
 REV H: TRANSIT UE UNIT CONNECTION DETAILS ADDED 02/04/07 MH  
 REV G: SPECIAL OPTION TRAILER CABLE COLOUR ALTERED 24/01/07 MH  
 REV F: 7 CORE TRAILER CABLE CHANGED FROM NUMBERED TO COLOURED 03/10/06 MH  
 REV E: CFD TO G3 LINK NOTE REMOVED 26/06/06 MH  
 REV D: POTENTIOMETER DETAIL ADDED 26/04/05 MH  
 REV C: TRAILER CABLE CHANGED TO PUMP MOTOR CABLE 21/07/04 MH  
 REV B: 'G3' TO 'CFD' LINK NOTE ADDED 07/04/03 MH  
 REV A: CONNECTION DETAILS ALTERED TO SUIT REVISED TRALER CONNECTION PCB 06/02/03 MH



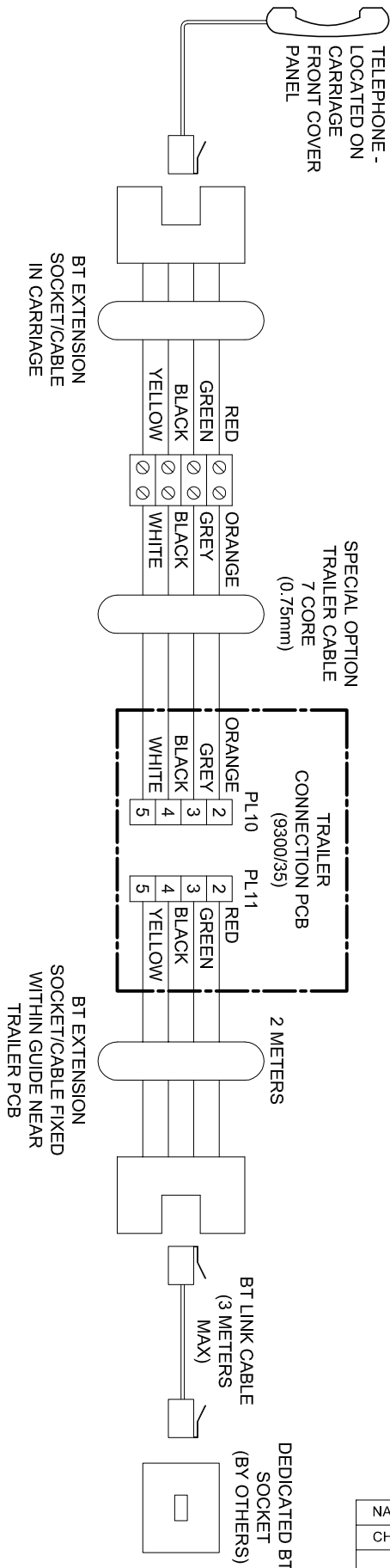

REV H: ORDER OF BT EXTENSION SOCKET CABLE WIRES CHANGED TO REFLECT MEMCOM INSTALLATION MANUAL DRAWING. 05/11/12 JK. A5364  
 REV G: UPDATED FOR NEW LOGO AND TEXT FONT. 13/09/2010 JN.  
 REV F: SPECIAL OPTION TRAILER CABLE COLOUR ALTERED 24/01/07 MH  
 REV E: 7 CORE TRAILER CABLE CHANGED FROM NUMBERED TO COLOURED 03/10/06 MH  
 REV D: BT EXTENSION CABLE COLOURS ALTERED 26/06/06 MH  
 REV C: SPECIAL OPTION TRAILER CABLE CHANGED FROM 12 TO 7 CORES 29/04/05 MH  
 REV B: CONNECTION DETAILS ALTERED 20/07/04 MH  
 REV A: BT EXTENSION SOCKET/CABLE ADDED 17/10/03 MH

NAME: H.HOOD	DATE: 22/10/02
CHECKED: R.BAUGH	DATE: 22/11/02
<b>MIDLIFT SL TELEPHONE OPTION CONNECTION DETAILS</b>	
HEAD OFFICE: Anton Mill Andover Hampshire SP10 2NX England Tel: 01264 339090 Fax: 337942	
<b>Stannah</b>	
DRAWING NO: 9444/19	REV: H

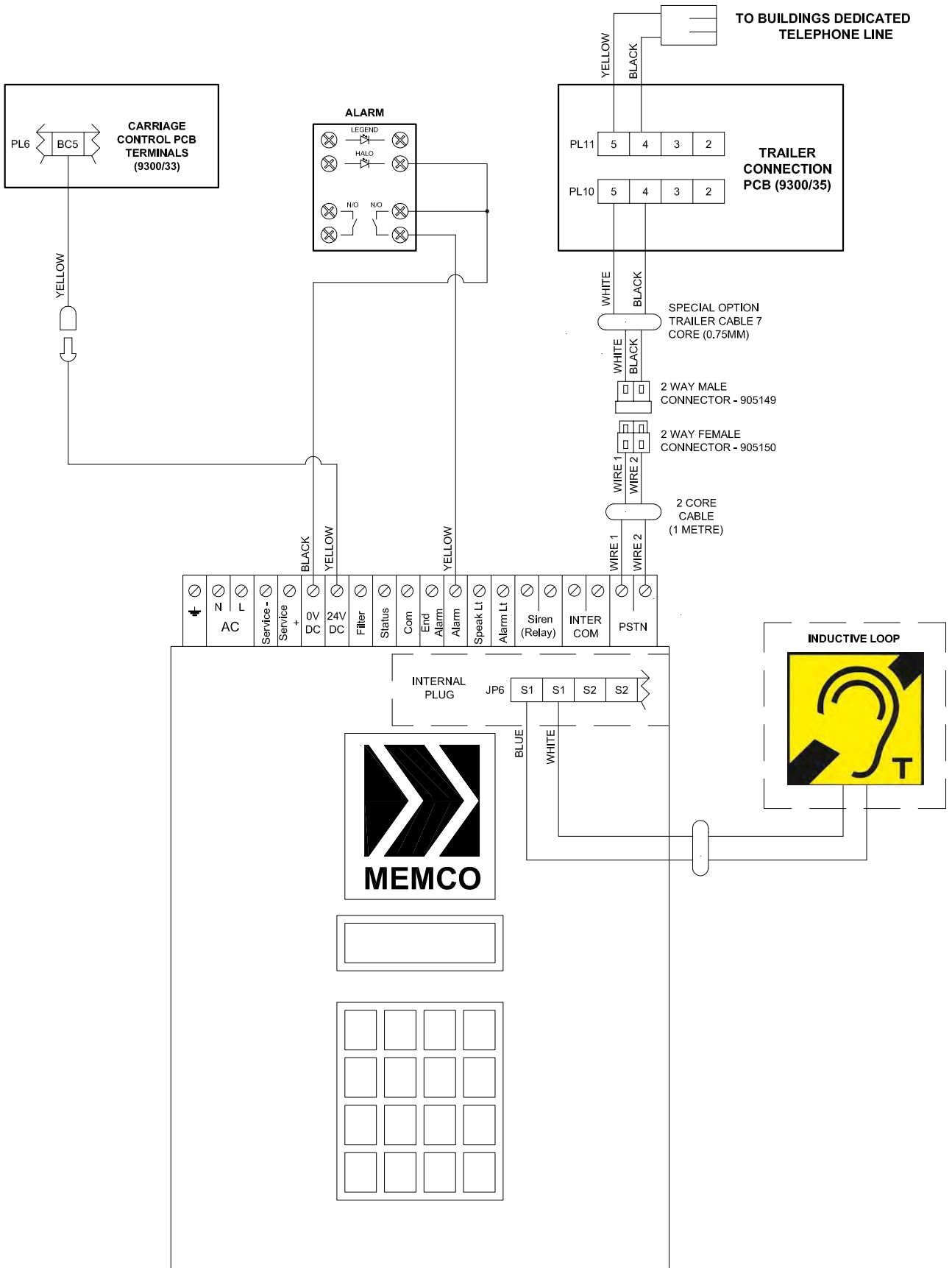

NAME: J.NICHOLLS	DATE: 24/08/10
CHECKED: M.HOOD	DATE: 28/08/10
<b>MIDILIFT SL AUTODIAL CONNECTION DETAILS</b>	
<b>Stannah</b>	
HEAD OFFICE: Anton Mill Andover Hampshire SP10 2NX England Tel: 01264 339090 Fax: 337942	
DRAWING NO: 9444/108	REV: A

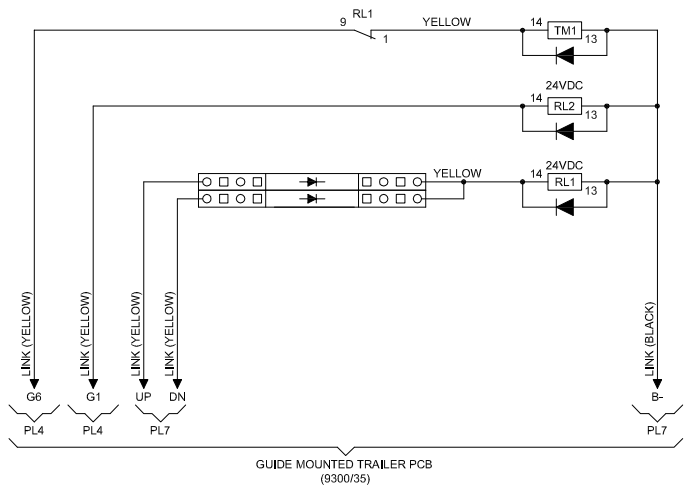
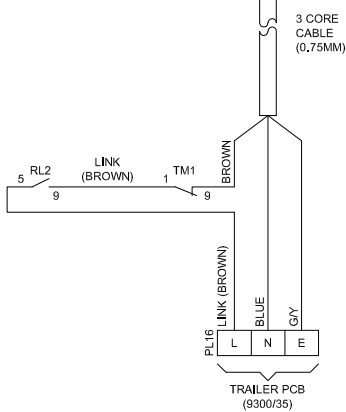
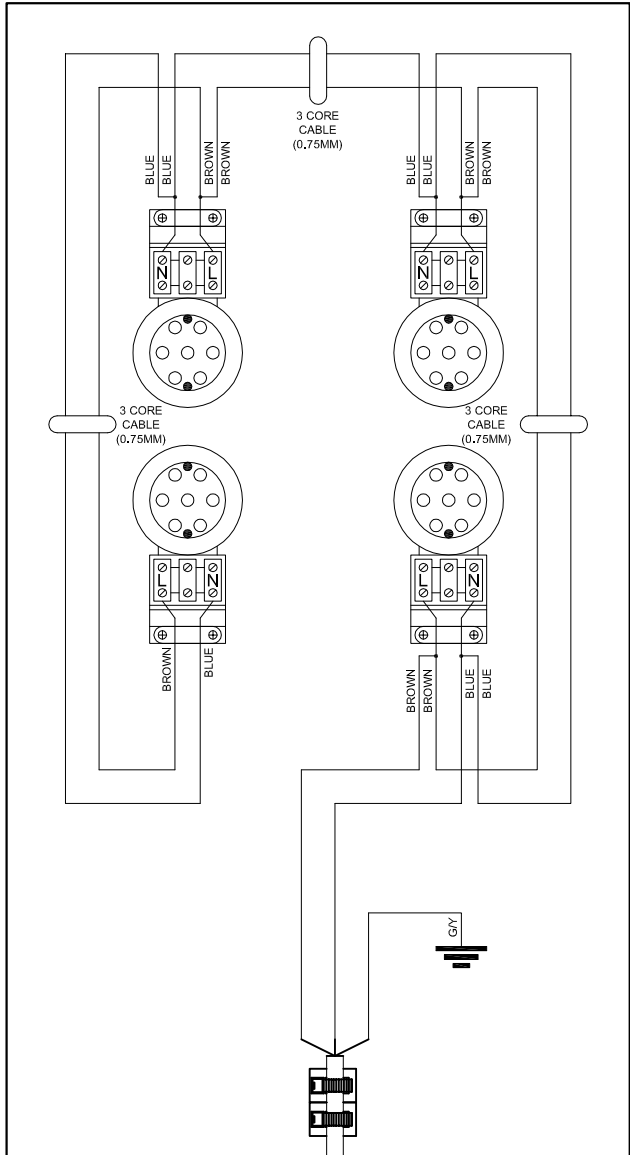

NAME: J.KENT	DATE: 02/07/12
CHECKED: M.HOOD	DATE: 02/07/12
<b>MIDLIFT SL SHAFT ROOF LED LIGHTING</b>	
<b>Stannah</b>	
HEAD OFFICE: Anton Mill Andover Hampshire SP10 2NX England	
Tel: 01264 339090 Fax: 337942	
DRAWING NO: 9444/126	REV:

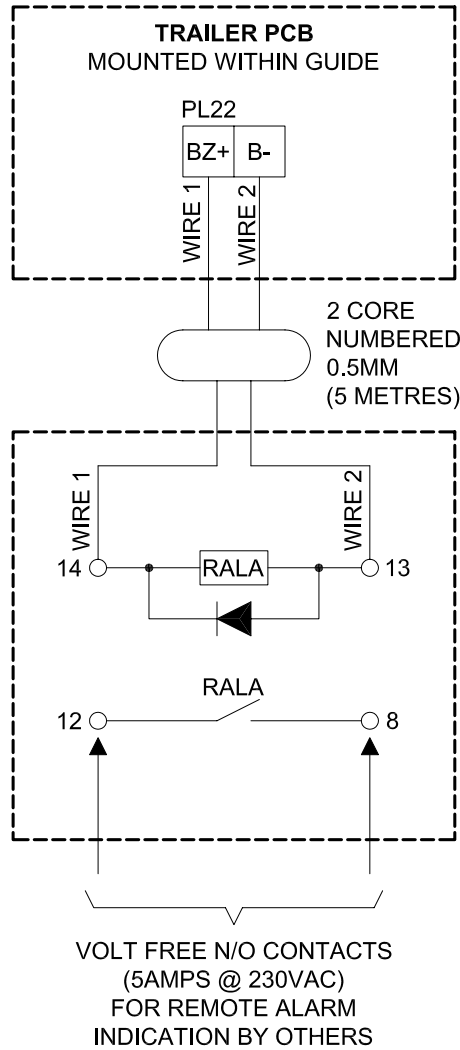

**IMPORTANT NOTE:**  
ENCLOSURE TO BE  
MOUNTED OUTSIDE OF  
THE LIFT WITHIN A 5  
METER RADIOUS AT THE  
LOWER LANDING

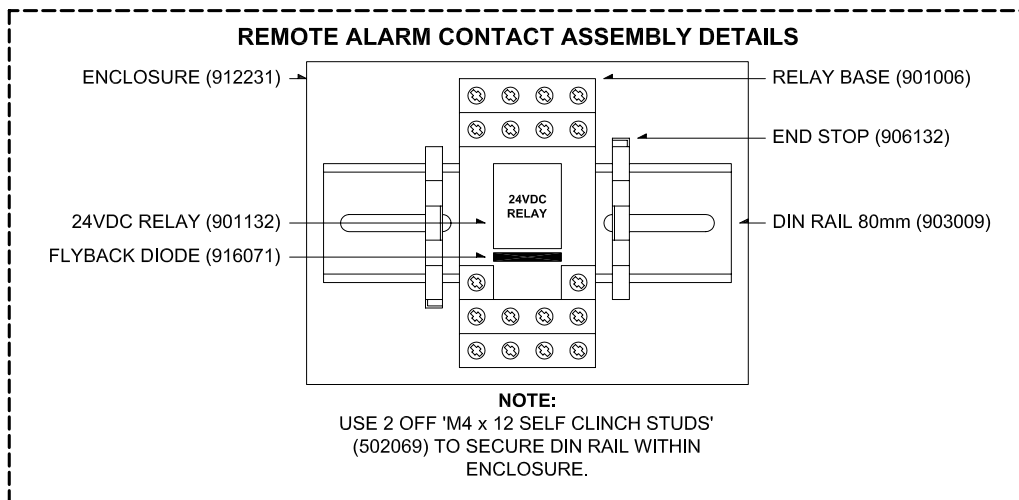

**IMPORTANT NOTE:**  
ON EXTERNAL CONTRACTS, ENSURE THAT  
CABLE ENTRY GLANDS ARE MOUNTED ON  
UNDERSIDE OF ENCLOSURE.

NAME: M.HOOD	DATE: 06/03/03
CHECKED: R.BAUGH	DATE: 06/03/03
MIDLIFT SL REMOTE ALARM FREE CONTACTS OPTION CONNECTIONS DETAILS	
<b>Stannah</b>	
HEAD OFFICE: Anton Mill Andover Hampshire SP10 2NX England	
Tel: 01264 339090 Fax: 337942	
DRAWING NO: 9444/32	REV: F

REV F: UPDATED FOR NEW LOGO AND TEXT FONT. 13/09/2010 JN.  
REV E: CONNECTIONS NOW TAKEN FROM TRAILER PCB TERMINALS 04/10/06 MH  
REV D: 7 CORE TRAILER CABLE CHANGED FROM NUMBERED TO COLOURED 03/10/06 MH  
REV C: SPECIAL OPTION TRAILER CABLE CHANGED FROM 12 TO 7 CORES 29/04/05 MH  
REV B: TRAILER CABLE CHANGED TO SPECIAL OPTION SO THAT INDICATORS CAN BE RUN FROM PUMP MOTOR TRAILER 21/07/04 MH  
REV A: TERMINATION OF TRAILER MOVED FROM ALARM PUSH TO BUZZER TERMINALS 09/10/03 MH

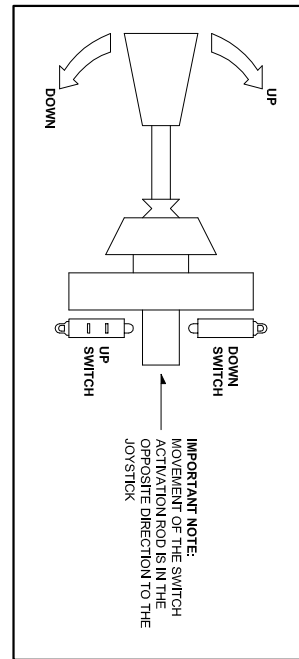
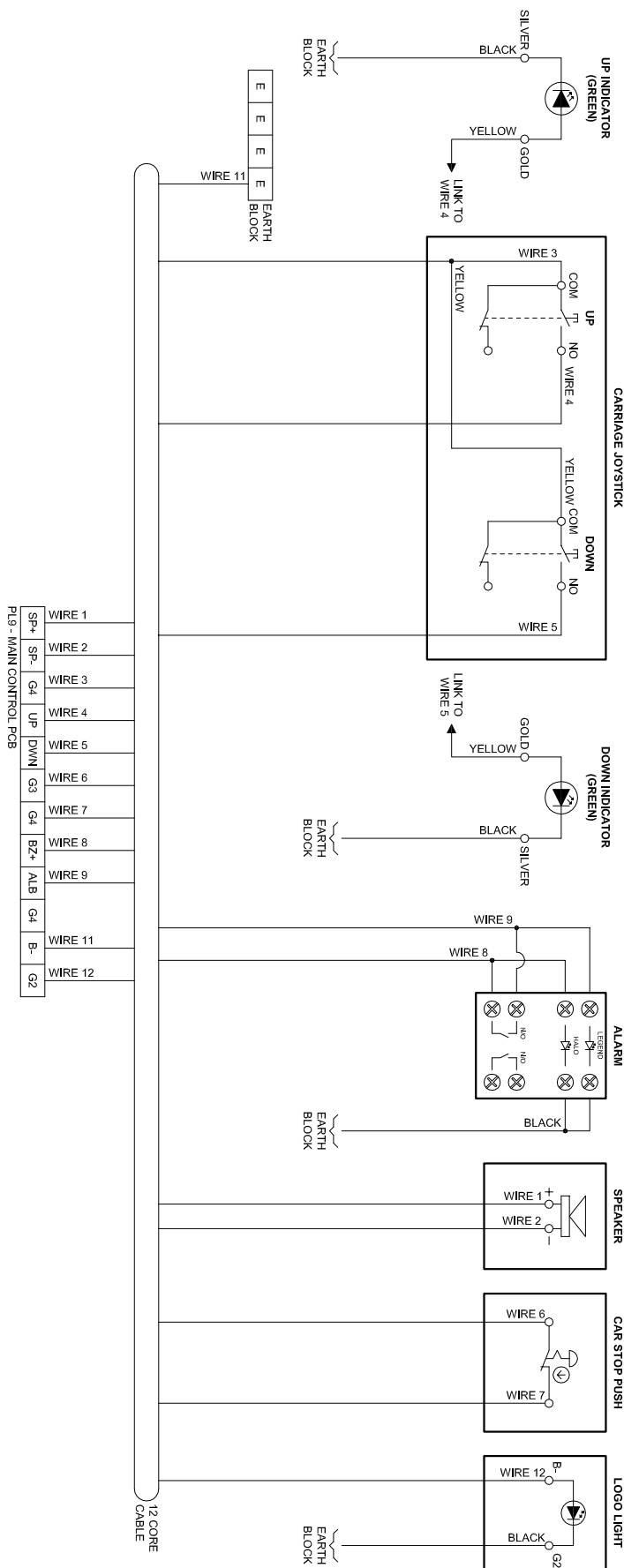

BURGESS JOYSTICK DETAILS

PL9 - MAIN CONTROL PCB

SP+	WIRE 1
SP-	WIRE 2
G4	WIRE 3
UP	WIRE 4
DWN	WIRE 5
G3	WIRE 6
G4	WIRE 7
BZ+	WIRE 8
ALB	WIRE 9
G4	
B-	WIRE 11
G2	WIRE 12

NAME: M.HOOD	DATE: 07/04/03
CHECKED: R.BAUGH	DATE: 07/04/03

MIDLIFT SL  
CARRIAGE COVER CONTROLS  
WITH JOYSTICK OPTION

**Stannah**

HEAD OFFICE:  
Anton Mill  
Andover Hampshire  
SP10 2NX England

Tel: 01264 339090 Fax: 337942

DRAWING NO: 9444/34

REV: G

REV G: TERMINAL LABELS ADDED TO JOYSTICK AND SPEAKER WIRING UPDATED. 30/11/2011 JK.A5115.  
 REV F: UPDATED FOR NEW LOGO AND TEXT FONT. 13/09/2010 JN.  
 REV E: CONNECTION DETAILS OF NEW DEWHURST 'M20' PUSH BUTTON SHOWN 27/05/09 MH  
 REV D: CONNECTION DETAILS OF NEW DEWHURST PUSH BUTTON SHOWN 02/04/07 MH  
 REV C: CARRIAGE COVER CONNECTIONS ALTERED AS CAR PREFERENCE IS MAINTAINED BY CPR RELAY 03/01/07 MH  
 REV B: OVERLOAD INDICATOR DELETED 20/07/04 MH  
 REV A: CONNECTION ALTERED TO SUIT NEW BURGESS JOYSTICK 30/06/03 MH

## CARRIAGE COVER MOUNTED DDU

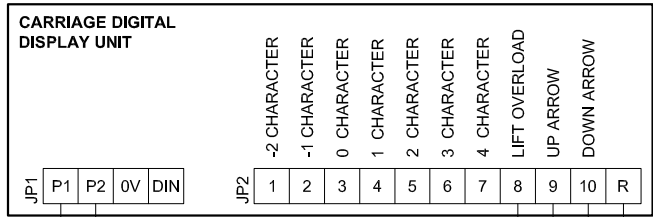

CARRIAGE COVER MOUNTED DDU's:  
HORIZONTAL UNIT ONLY: 912260

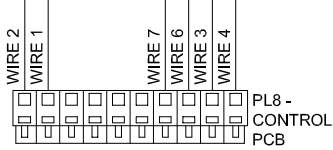
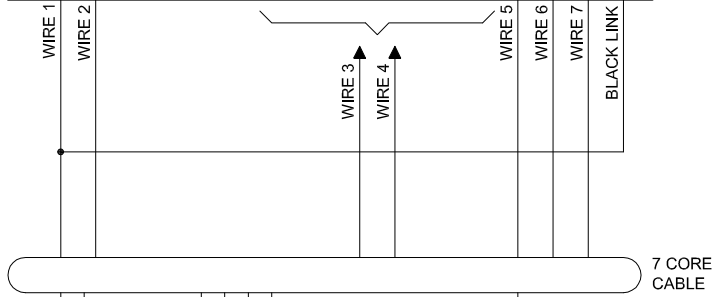

FOR FEMALE CONNECTIONS  
SEE 9444/57

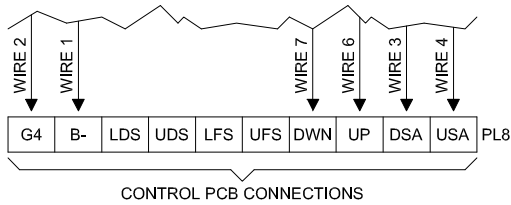

REV F: REFERENCE DRAWING NUMBER UPDATED. 24/04/2012 JN ECN 5281.  
REV E: UPDATED FOR NEW LOGO AND TEXT FONT. 13/09/2010 JN.  
REV D: LANDING STATION CONNECTIONS REMOVED 27/05/09 MH  
REV C: UPPER LANDING GONG CONNECTION DETAILS AMENDED 20/05/08 MH  
REV B: ALTERNATIVE WIRING SHOWN FOR CONTRACTS WITH NO LANDING DDU 08/11/07 MH  
REV A: USA AND DSA TERMINATIONS ALTERED 17/09/04 MH

NAME: M.HOOD	DATE: 20/07/04
CHECKED: R.BAUGH	DATE: 20/07/04
<b>MIDLIFT SL</b> <b>CARRIAGE COVER DDU</b> <b>CONNECTION DETAILS</b>	
HEAD OFFICE: Anton Mill Andover Hampshire SP10 2NX England	
Tel: 01264 339090 Fax: 337942	
DRAWING NO: 9444/48	REV: F

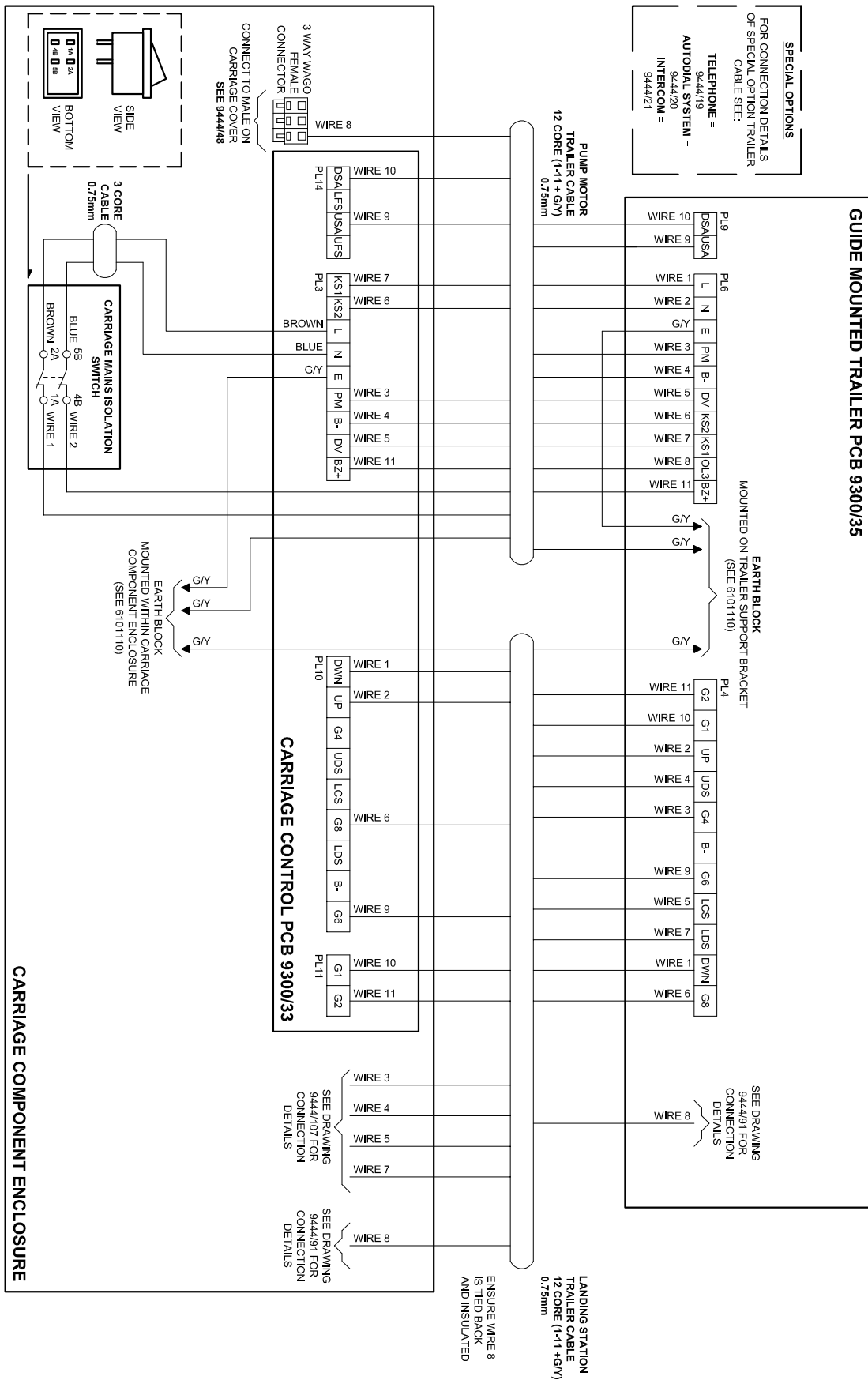

NAME: M.HOOD	DATE: 25/04/05
CHECKED: D.GASPARI	DATE: 25/04/05
<b>MIDLIFT SL TRAILER CABLE CONNECTION DETAILS</b>	
HEAD OFFICE: Anton Mill Andover Hampshire SP10 2NX England Tel: 01264 339090 Fax: 337942	
DRAWING NO: 9444/57	REV: G

REV G: MAINS ISOLATION SWITCH CONNECTIONS CHANGED TO REFLECT XL+ AND MULTI. 05/07/2012 JK. A5293  
 REV F: WIRING ALTERED TO MONITOR UAS & DSA. 03/02/2012 JN. ECN5257  
 REV E: UPDATED FOR NEW LOGO AND TEXT FONT. 13/09/2010 JN.  
 REV D: WIRES 5&8 ON TRAILER 2 RELOCATED, TO INCORPORATE LATCH LANDINGS & FIRE ALARM SHUTDOWN. 13/05/10 JN. A4476  
 REV C: ADDITIONAL DETAIL ADDED TO THE MAINS ISOLATION SWITCH CONNECTIONS 20/05/08 MH  
 REV B: BZ+ TERMINAL - WIRE 11 CONNECTION DETAILS ADDED 02/04/07 MH  
 REV A: BZ+ TERMINAL ADDED TO PUMP MOTOR TRAILER CABLE CONNECTION 28/06/06 MH

**SL 2 STOP UPS ENCLOSURE**

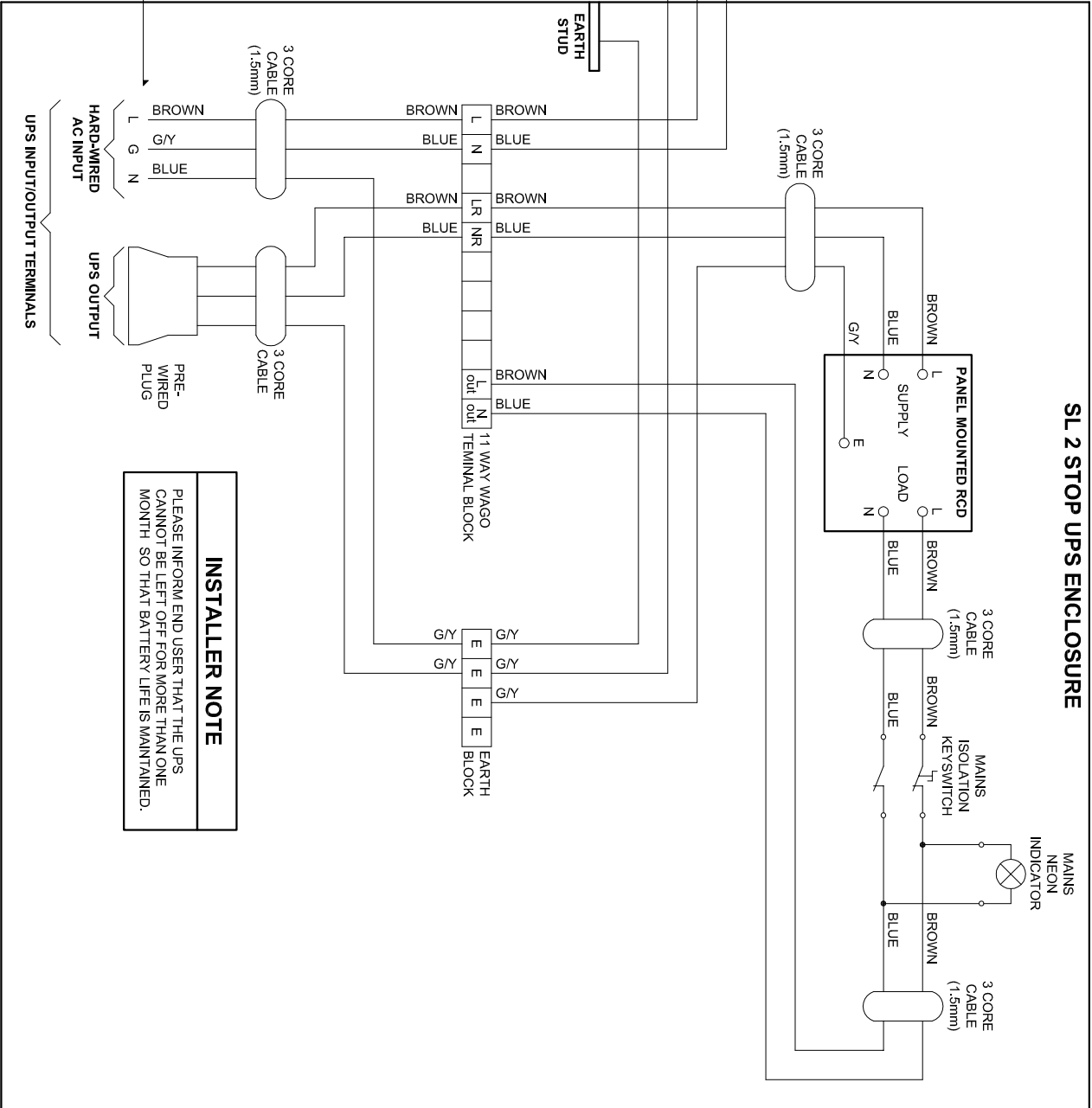

**INSTALLER NOTE**  
COMPLETE CONNECTION USING 3 CORE PROVIDED.

**INSTALLER NOTE**  
PLEASE INFORM END USER THAT THE UPS CANNOT BE LEFT OFF FOR MORE THAN ONE MONTH SO THAT BATTERY LIFE IS MAINTAINED.

NAME: M.HOOD DATE: 27/04/05  
CHECKED: R.BAUGH DATE: 27/04/05

**SL 2 STOP UPS CONNECTION DETAILS**

**Stannah**

HEAD OFFICE:  
Anton Mill  
Andover Hampshire  
SP10 2NX England  
Tel: 01264 339090 Fax: 337942

REV B: UPDATED TO REFLECT NEW HARD WIRED INPUT UPS UNIT. 05/12/2011 JK. A5115.  
REV A: UPDATED FOR NEW LOGO AND TEXT FONT. 13/09/2010 JN.

DRAWING NO: 9444/58 REV: B



**CARRIAGE COMPONENT ENCLOSURE**

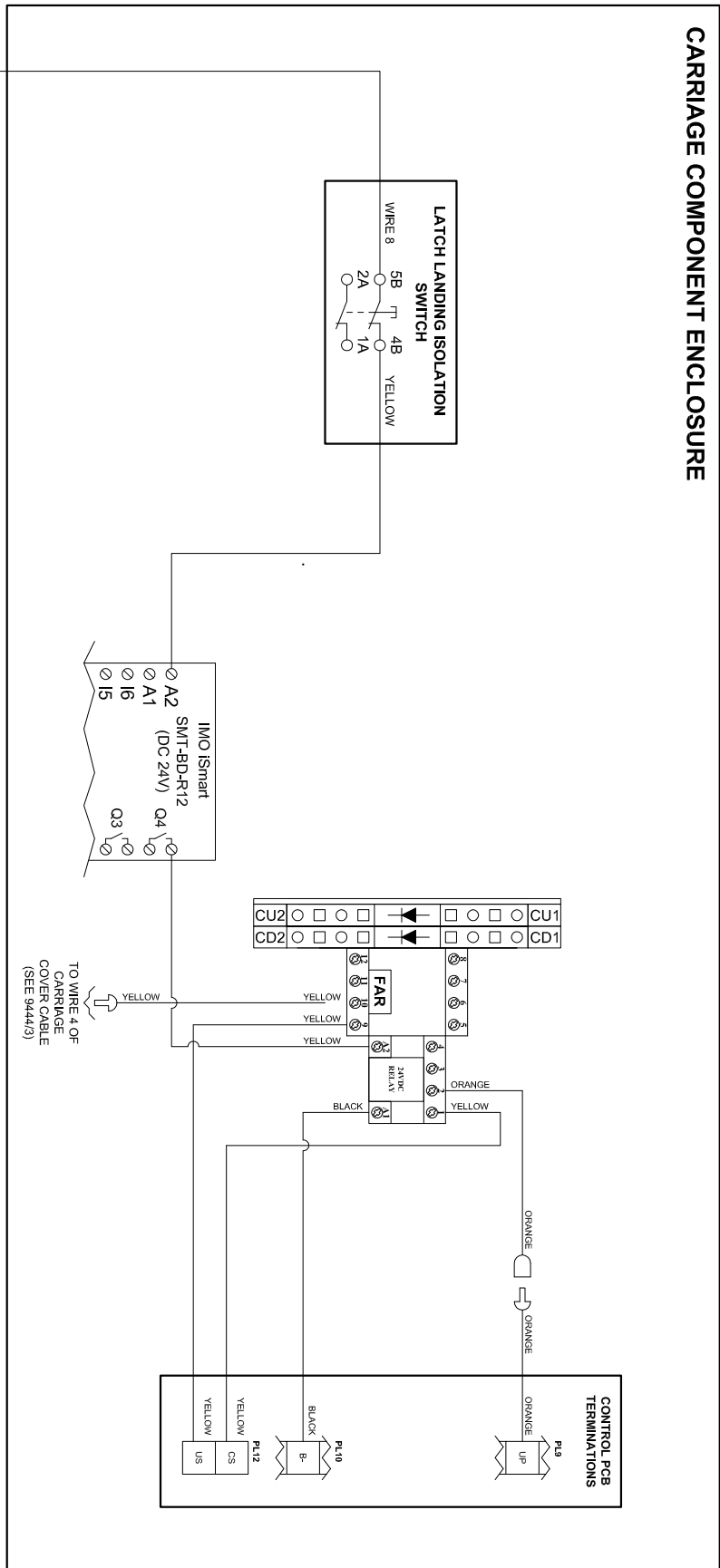

**IMPORTANT NOTE:**  
ENCLOSURE TO BE MOUNTED  
OUTSIDE OF THE LIFT WITHIN A  
5 METER RADIOUS AT THE  
LOWER LANDING

REV C: REMOVED YELLOW LINK ON CD1 TERMINAL. 05/07/2012 JK. A5293  
 REV B: ALTERED WIRING TO A2 TERMINAL ON RELAY 'FAR' AND UPDATED FOR NEW LOGO AND TEXT FONT. 25/02/2011 JN.  
 REV A: LFS RELAY REMOVED AND PLC CONTACT ADDED TO INCORPORATE LATCH LANDINGS. 07/05/10 JN. A4476

NAME: M.HOOD	DATE: 30/09/08
CHECKED: R.BAUGH	DATE: 30/09/08
<b>MIDLIFT SL - RELAY ASSEMBLY DETAIL FOR FIRE ALARM SHUTDOWN TO GROUND FLOOR</b>	
<b>Stannah</b>	
HEAD OFFICE: Anton Mill Andover Hampshire SP10 2NX England Tel: 01264 339090 Fax: 337942	
DRAWING NO: 9444/91	REV: C

**SAFETY NOTE:**

ISOLATE THE LATCH LANDINGS AND FIRE ALARM SHUTDOWN CIRCUIT USING THE 'LATCH LANDINGS ISOLATION' SWITCH DURING INSTALLATION, INSPECTION AND WHENEVER CARRIAGE COVER IS REMOVED.

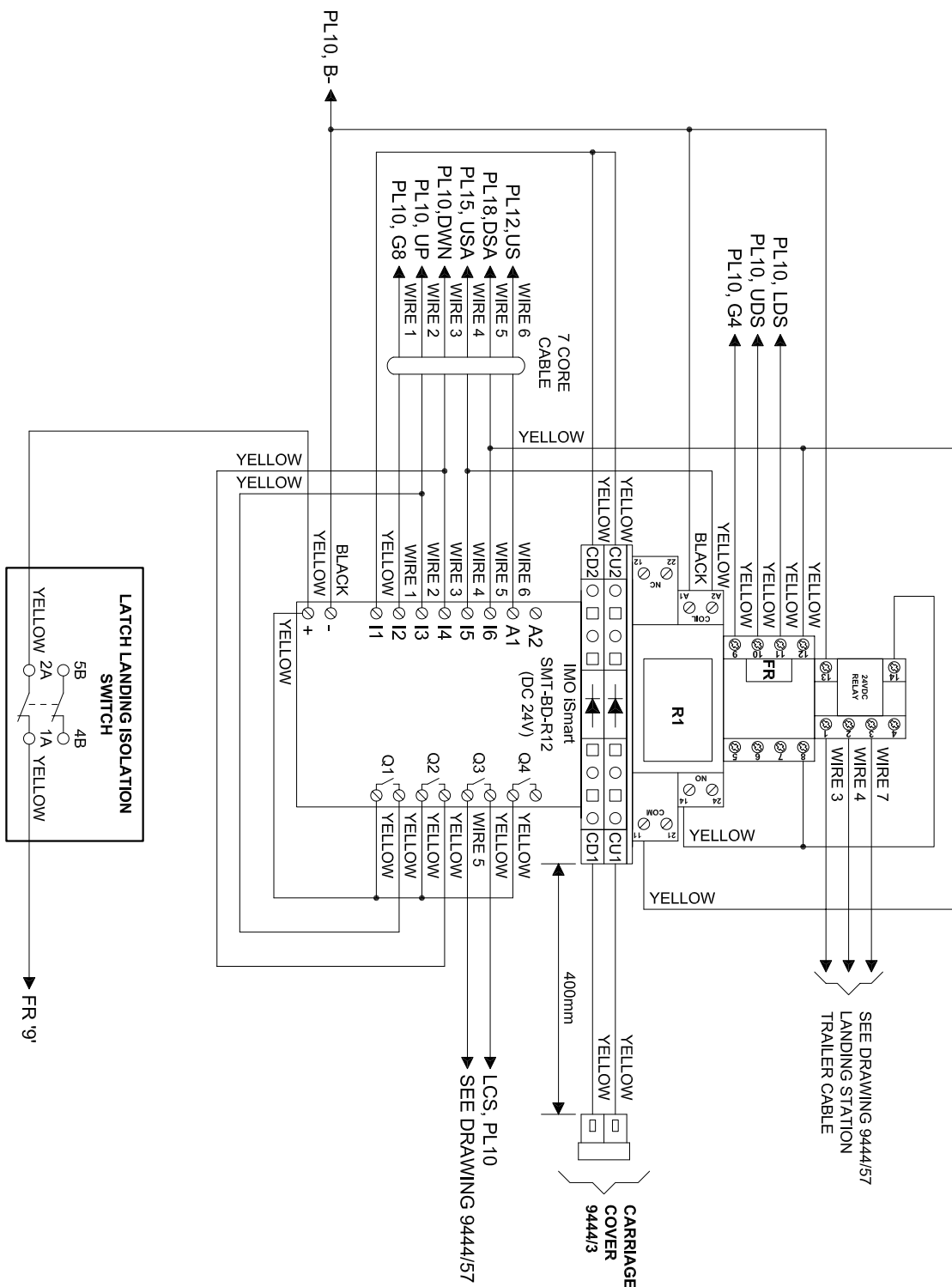

NAME: J.NICHOLLS	DATE: 13/01/10
CHECKED: M.HOOD	DATE: 13/01/10
MIDLIFT SL PLC CONNECTION DETAILS	
	
HEAD OFFICE: Anton Mill Andover Hampshire SP10 2NX England Tel: 01264 339090 Fax: 337942	
DRAWING NO: 9444/107	REV: C

REV C: PL10 'DSA' CONNECTION REMOVED. 20/02/2012 JK. A5281  
 REV B: RELAYS ADDED AND WIRING ALTERED TO MONITOR UAS & DSA. 03/02/2012 JN. ECN5257  
 REV A: LINK WIRE POSITION CHANGED & UPDATED FOR NEW LOGO AND TEXT FONT. 13/09/2010 JN.

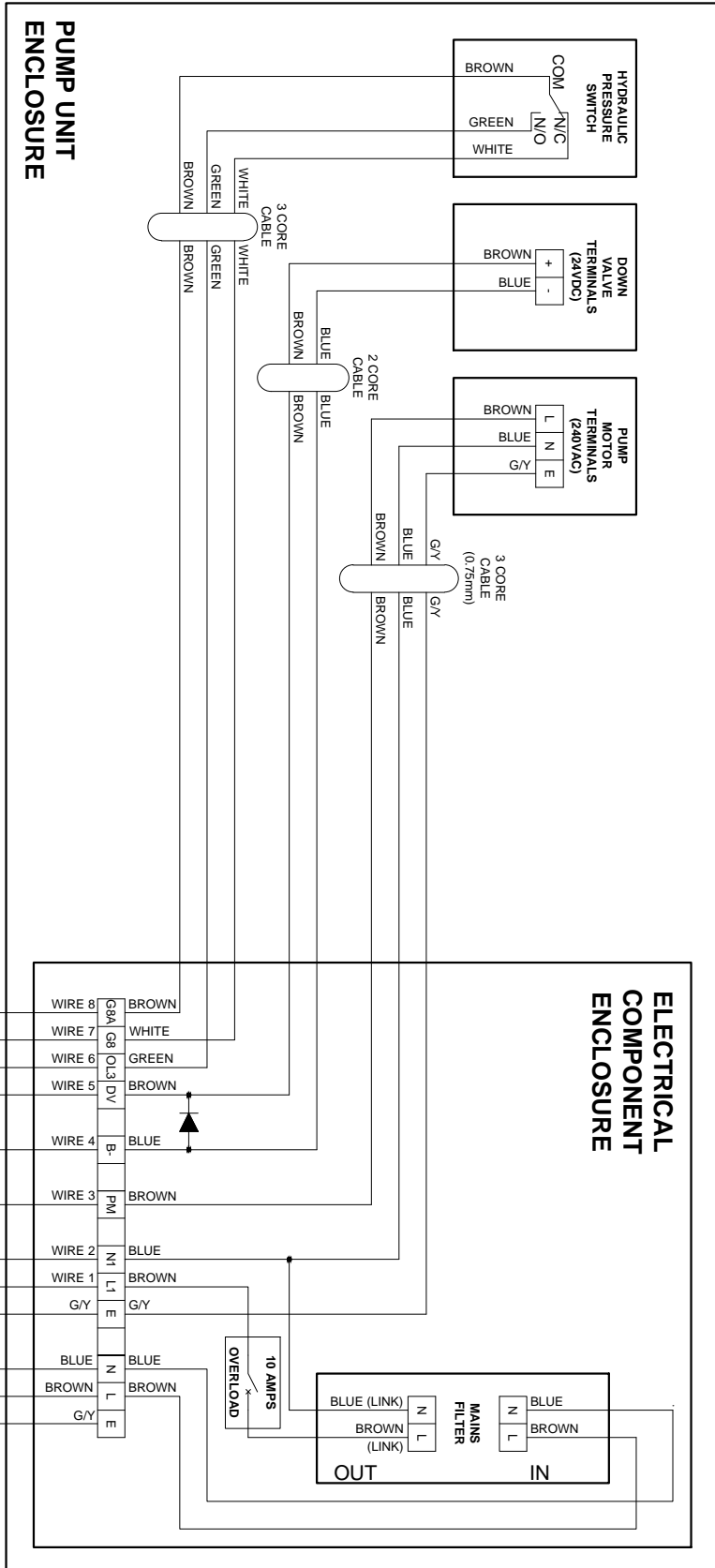

**EARTH BONDING**

SEE DRAWING 6101110 FOR EARTH BONDING  
DETAIL OF MIDLIFT SL

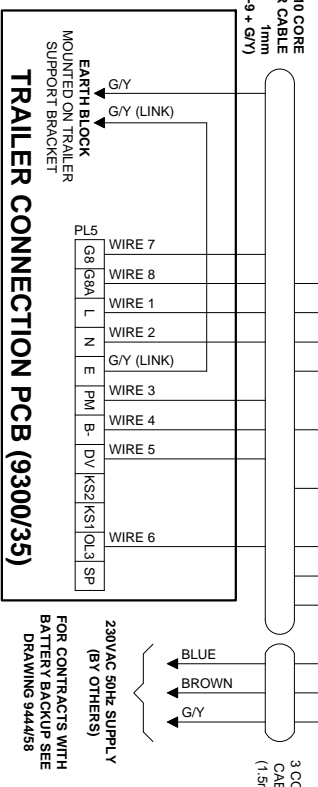

NAME: J.NICHOLLS	DATE: 16/08/13
CHECKED: M.HOOD	DATE: 16/08/13
<b>MIDLIFT SL - PUMP UNIT CONNECTION DETAILS (0.15m/s)</b>	
<b>Stannah</b>	
HEAD OFFICE: Anton Mill Andover Hampshire SP10 2NX England Tel: 01264 339090 Fax: 337942	
DRAWING NO: 9444/132	REV: C

REV C: AMENDED TO REMOVE IGV FROM TITLE BLOCK. MH 24-02-14 ECN5562  
 REV B: FLYBACK DIODE ADDED BETWEEN B- AND DV. JN 09-09-13  
 REV A: INTERNAL WIRE NUMBERS CHANGED TO COLOURS TO REFLECT IGV REV 2 DRAWING AND PL5  
 WIRING CORRECTED DUE TO INCORRECT WIRING OF PRESSURE SWITCH. JN 04-09-13

# STANDARD HANDSET

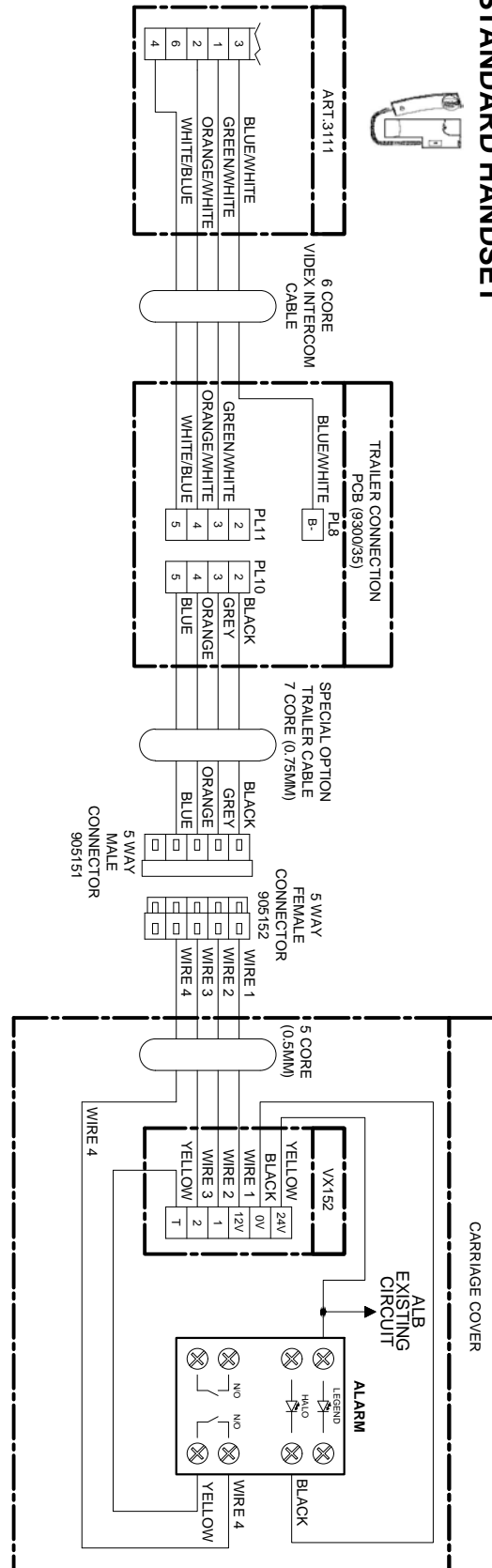

# SIMPLEX OPTION

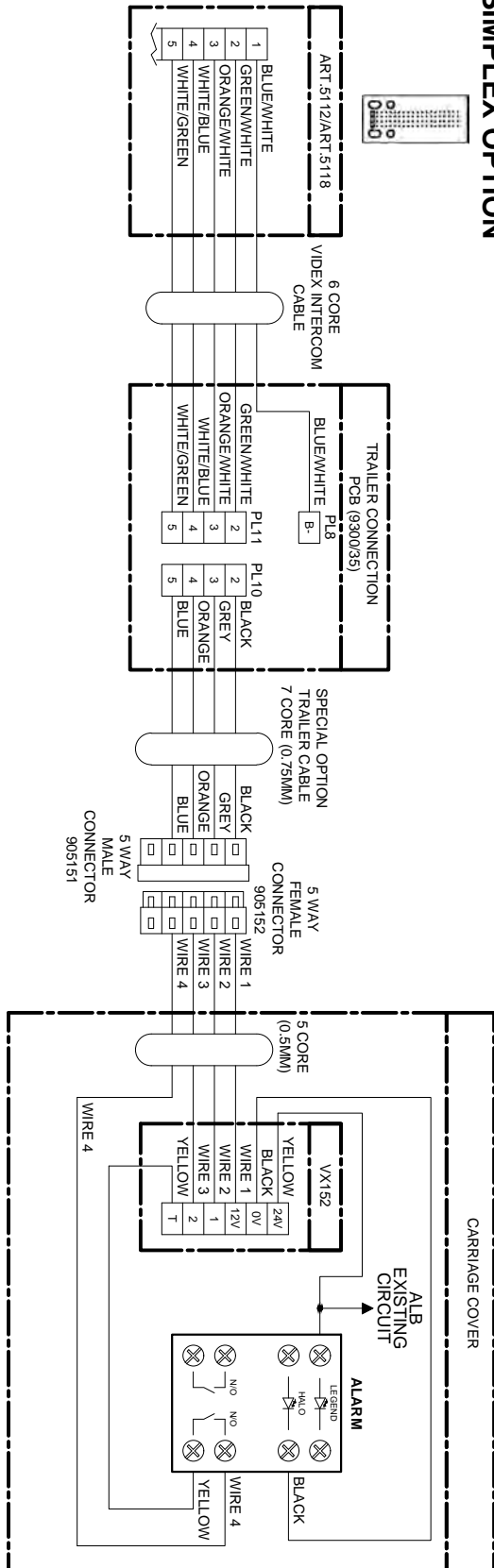
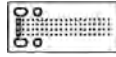

NAME: J.KENT DATE: 09/04/13  
 CHECKED: M.HOOD DATE: 09/04/13

## MIDLIFT SL 2 STOP VIDEK INTERCOM CONNECTION DETAILS

HEAD OFFICE:  
 Anton Mill  
 Andover Hampshire  
 SP10 2NX England  
 Tel: 01264 339090 Fax: 337942

DRAWING NO: 9444/131 REV: A

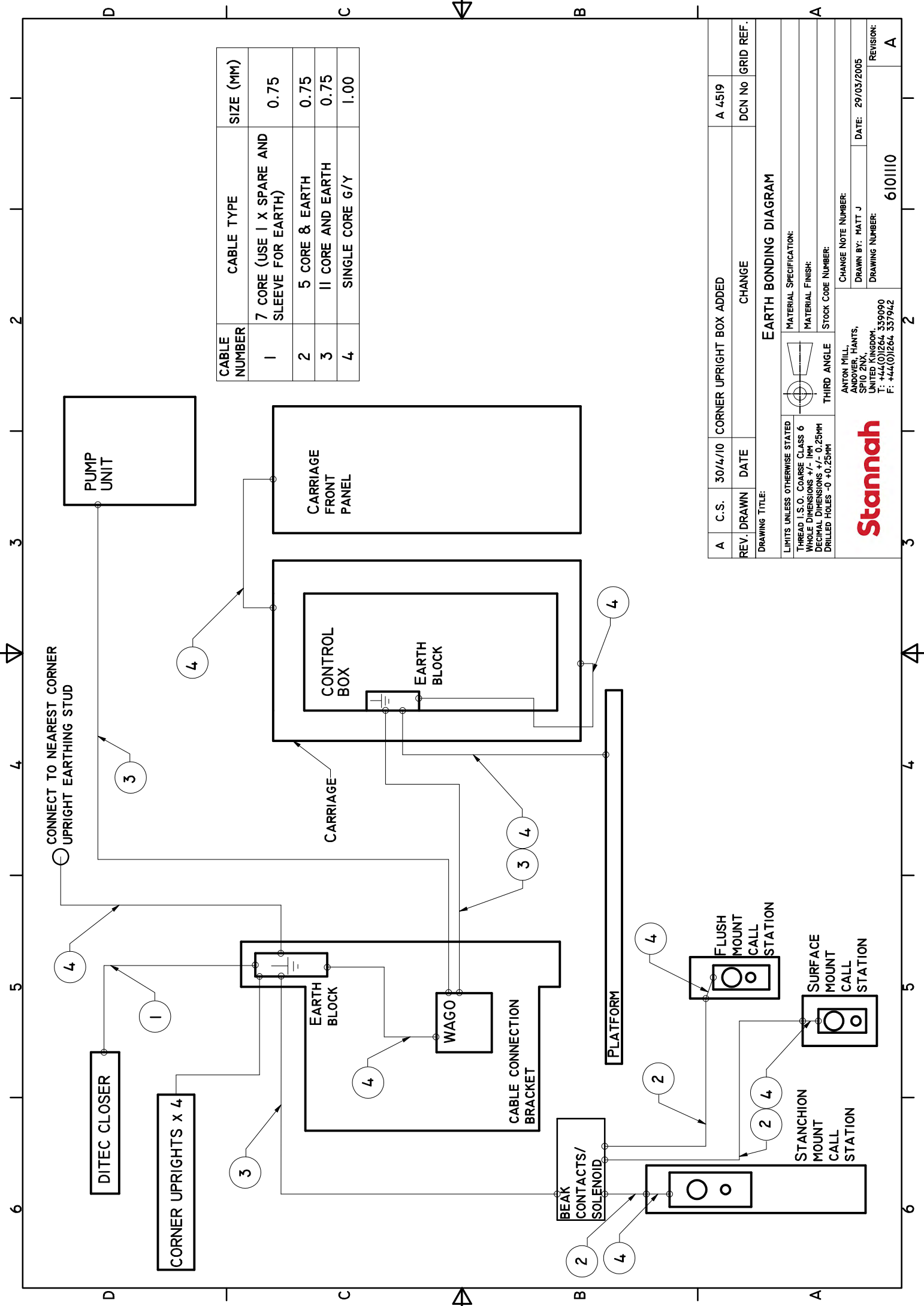

CABLE NUMBER	CABLE TYPE	SIZE (MM)
1	7 CORE (USE 1 X SPARE AND SLEEVE FOR EARTH)	0.75
2	5 CORE & EARTH	0.75
3	11 CORE AND EARTH	0.75
4	SINGLE CORE G/Y	1.00

A	C.S.	30/4/10	CORNER UPRIGHT BOX ADDED	CHANGE	A 4519
REV.	DRAWN	DATE			DCN No
DRAWING TITLE: EARTH BONDING DIAGRAM					
LIMITS UNLESS OTHERWISE STATED					
THREAD I.S.O. COARSE CLASS 6					
WHOLE DIMENSIONS +/- 1MM					
DECIMAL DIMENSIONS +/- 0.25MM					
DRILLED HOLES -0 +0.25MM					
MATERIAL SPECIFICATION:			MATERIAL FINISH:		
THIRD ANGLE			STOCK CODE NUMBER:		
ANTON MILL, ANDOVER, HANTS, SP10 2XA, UNITED KINGDOM. T: +44(0)1264 339090 F: +44(0)1264 337942					
CHANGE NOTE NUMBER: DRAWN BY: MATT J DATE: 29/03/2005					
DRAWING NUMBER: 6101110					
REVISION: A					

